



"Brass is the new Black &
the ultimate sophistication"

SoHo
collection



New SoHo collection

SoHo is the new light switch collection from FEDE+.

Trendy and eclectic!

The **SoHo** range offers a modern design available in our stunning brushed finishes. You can select the brushed finish in **brass, copper, graphite or nickel.**

Our craftsmen with their years of experience, artistic eye and incredible skills have created these **very original brushed finishes.**

The timeless beauty and ability to be perfectly matched with any colour scheme means the new **SoHo** switch collection is a **“must have” for your next interior design project.**





BRUSHED Nickel

BRUSHED Graphite

BRUSHED Brass

BRUSHED Copper

The importance of the material and the finish

At FEDE, we love brass. A noble metal which allows us to fashion the most sensational and sophisticated designs and finishes.

We are constantly developing new techniques that we apply to the production process, the polishing and the electrolytic bath to give a perfect finish.

Shinny is out. The new trend is matt and we are paving the way.

SoHo
collection

SoHo
collection

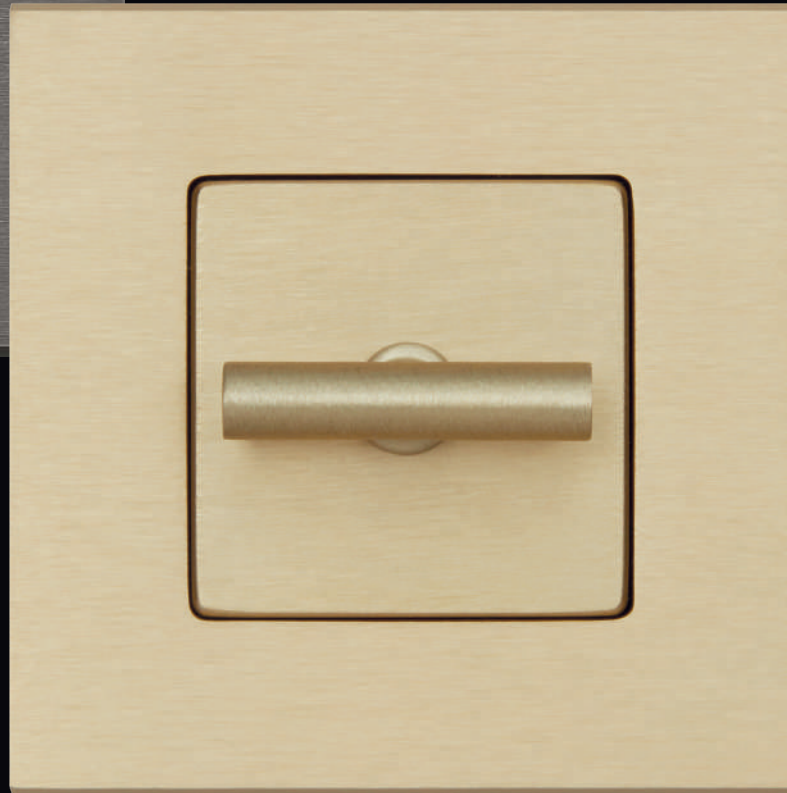
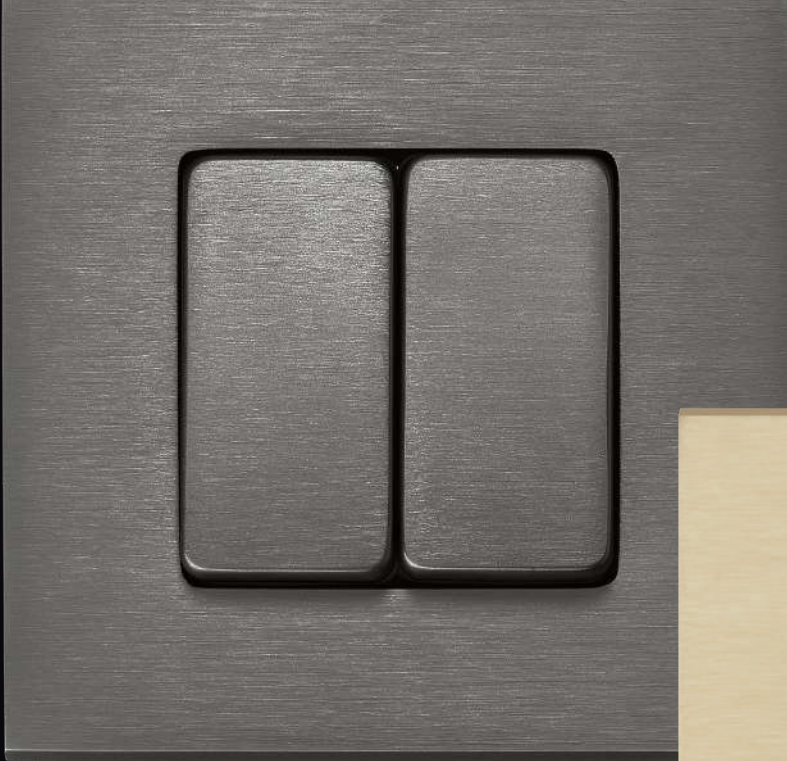

"Brass is the new Black &
the ultimate sophistication"

Minimalism

Minimalism is expressed in terms of pure straight lines. Less is more...

The simplicity takes on a new complex and sophisticated dimension in minimalist spaces.

What is essential is the simplicity itself. We eliminate all that is superfluous and we focus on the object: the essential element of a switch frame is its square form and the material from which it is made.

SoHo is our minimalist collection designed for projects that require the authenticity of brass and a switch design in its purest form; flat, straight and square.

SoHo
collection

9 mm



85 mm



85 x 85 mm
SQUARE

Design

SoHo is our new emblematic collection representing our firm and laying the foundation for the new trend in switch design.

For the last **10 years** we have developed a wide range of classical decorative switches and now it's time to reinvent ourselves once again.

Classic designs are never out of fashion, but now we are launching our new contemporary lines such as the **SoHo**.



SoHo
collection

DESIGN, EVOLUTION & REVOLUTION

*ITEMS' REAL SIZE ARE SHOWN IN THE IMAGES



Real shape & All in metal!

What do you prefer for your project?

- 1- Press switch with key.
- 2- Turn the rotary switch.
- 3- Switch the toggle.
- 4- Turn the dimmer.

SLIM & CLASSY!

CHOICE OF FRAME (SWITCH PLATE)

BRUSHED Nickel

BRUSHED Graphite

BRUSHED Brass

BRUSHED Copper

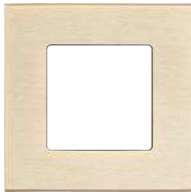

FRAMES

SIZE (mm)

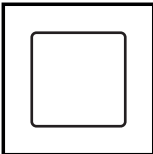

85x85

FD01701BN

FD01701BG

FD01701BB

FD01701BC

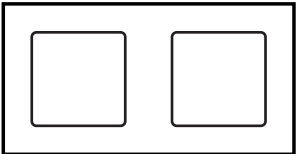

85x161

FD01702BN

FD01702BG

FD01702BB

FD01702BC

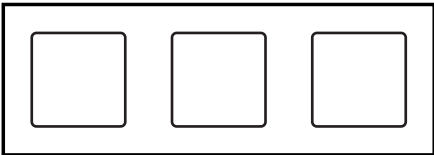

85x232

FD01703BN

FD01703BG

FD01703BB

FD01703BC

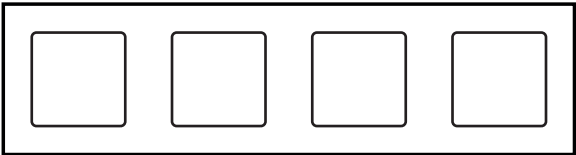

85x303

FD01704BN

FD01704BG

FD01704BB

FD01704BC

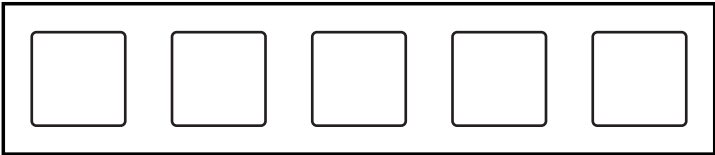

85x374

FD01705BN

FD01705BG

FD01705BB

FD01705BC

For other finishes, please contact our Sales Department.

INDEX

NEW SoHo COLLECTION	1	NEW HOTEL CARD SWITCH	42
INDEX	8	AUDIO RECEIVER	44
SWITCHES	9	SOCKETS	46
Switch with Keys	13	TV/SAT SOCKET OUTLETS	50
Toggle Switch	19	MULTIMEDIA CONNECTORS	53
Rotary Switch	23	THERMOSTATS	56
Infrared Light Switch	26	OTHER ELECTRICAL MECHANISMS	58
Switch for Blinds	27	INSTALLATION ACCESORIES	60
DIMMERS		INSTALLATION EXAMPLES	62
Touch	28	TECHNICAL DATA	64
Rotary	29		
Push Button	31		
NIGHT LIGHT INDICATOR	38		
NEW USB CHARGER	40		

NEW TOGGLE SWITCHES WITH LED LIGHT



NEW!



The same type of mechanism is used for lighted and non-lighted switches.

LED lights are installed in the switch mechanism by applying slight pressure, connecting automatically.

If necessary, you can change your common switch into a lighted switch. To do this, simply install the LED light and replace the opaque key with the diffuser key.

Switch mechanisms are available in two options: 10 and 16 A.

State-of-the-art LED lights with a longer service life are used in our switches mechanisms.

SoHo
collection

MAXIMUM FLEXIBILITY

The same switch mechanisms are used in both toggle switches and switches with keys. Thanks to our system's versatility, you can always easily change the design of already installed switches without performing complicated electrical work for their assembly.

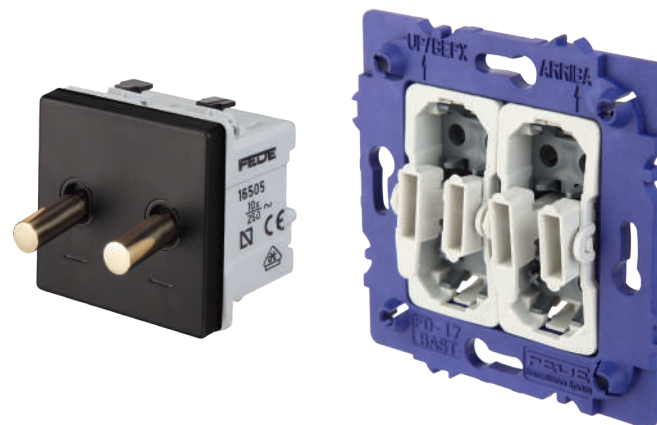

For two-key switches, both mechanisms are installed in the fixing support. Different types of switch mechanisms can be combined, such as a simple switch and a two-way switch.

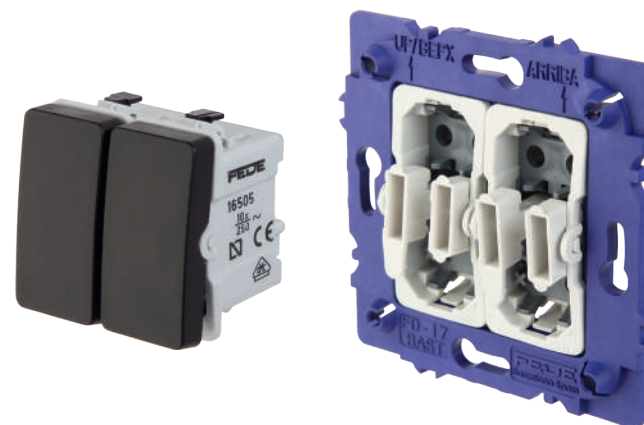

For single key switches, the mechanism is installed in the central part of the fixing support.



MODULAR SYSTEM

The modular structure of the SoHo collection guarantees a maximum flexibility when being installed. Our wide range of electronic mechanisms allows for an optimal technical solution.



The holes allow for the mounting supports (brackets) to be aligned.

The notches on the edges allow the mounting supports (brackets) to be easily connected.

Most items, with the exception of complex electronic devices, are supplied disassembled without keys or front plates, i. e., any decisions regarding appearance can be taken during the project's final stage.

All system elements are connected through a clip system to ensure easy installation.

SoHo
collection

A MODULAR & UNIVERSAL system



In the **SoHo collection**, we offer a wide range of decorative frames with the possibility to install up to five mechanisms. Our decorative frames are universal and may be installed in both horizontal and vertical positions.



Switch with Brass Keys

For those who appreciate the real touch of metal, we have designed keys in real brass with a high-quality electroplated surface.

The combination of the shine of the brass surface and the matte finish of the decorative frames results in true elegance and sophistication.

BRASS KEYS/TOUCHES EN LAITON/SCOCHE IN OTTONE/
TECLAS DE LATÓN/METALL-SCHLÜSSEL/ЛАТУННЫЕ КЛАВИШИ

BRUSHED Nickel



FD04310BN



FD04312BN

With diffuser
for LED lamp



FD04311BN



FD04313BN

With diffuser
for LED lamp

BRUSHED Graphite



FD04310BG



FD04312BG

With diffuser
for LED lamp



FD04311BG



FD04313BG

With diffuser
for LED lamp

BRUSHED Brass



FD04310BB



FD04312BB

With diffuser
for LED lamp



FD04311BB



FD04313BB

With diffuser
for LED lamp

BRUSHED Copper



FD04310BC



FD04312BC

With diffuser
for LED lamp



FD04311BC



FD04313BC

With diffuser
for LED lamp

PLASTIC WIDE KEYS/TOUCHES LARGES EN PLASTIQUE/TASTI LARGHI IN PLASTICA/
TECLAS ANCHAS DE PLÁSTICO/BREITE KUNSTSTOFFTASTEN/ПЛАСТИКОВЫЕ КЛАВИШИ

WHITE BEIGE BLACK



FD17705-L



FD17705-AL



FD17705-ML

WHITE BEIGE BLACK



FD17705



FD17705-A



FD17705-M

PLASTIC NARROW KEYS/TOUCHES ÉTROITES EN PLASTIQUE/TASTI STRETTI IN PLASTICA/
TECLAS ESTRECHAS DE PLÁSTICO/SCHMALE KUNSTSTOFFSCHLÜSSEL/
ПЛАСТИКОВЫЕ КЛАВИШИ

WHITE BEIGE BLACK



FD16705-L



FD16705-AL



FD16705-ML

WITH DIFFUSER
AVEC LUMIÈRE
CON DIFFUSORE
CON DIFUSOR
MIT DIFFUSOR
С ДИФФУЗОРОМ

WITHOUT DIFFUSER
SANS LUMIÈRE
SENZA
DIFFUSORE
SIN DIFUSOR
OHNE DIFFUSOR
БЕЗ ДИФФУЗОРА



FD16705



FD16705-A



FD16705-M

LIGHT INDICATORS/VOYANT/INDICATORE LUMINOSO/SEÑALIZADOR LUMINOSO/LEUCHTANZEIGE/СИГНАЛЬНЫЕ ЛАМПЫ



FD21139-1

Blue LED indicator for DP switches and intermediate switches 230 V~ 1mA
Indicateur LED bleu pour interrupteurs DP et interrupteurs intermédiaires 230 V - 1mA
Indicatore LED blu per interruttori DP e meccanismi incrociati 230 V - 1mA
Señalizador de LED azul para interruptores bipolares y cruzamiento 230 V~ 1mA
Blaue LED-Anzeige für DP Ausschalter und Kreuzschalter 230V ~ 1mA



FD21139-2

Blue LED indicator for SP switches, push-buttons and two-way switches 230 V~ 1mA
Indicateur LED bleu pour interrupteurs SP, bouton-poussoir et interrupteurs va et vient 230 V - 1mA
Indicatore LED blu per interruttori SP, pulsanti e commutatori 230 V - 1mA
Señalizador de LED azul para interruptores unipolares, pulsadores y conmutadores. 230 V~ 1mA
Blaue LED-Anzeige für SP Ausschalter, Taster und Wechselschalter 230V ~ 1mA

ADDITIONAL RESISTANCE / RÉSISTANCE SUPPLÉMENTAIRE / RESISTENCIA ADICIONAL/ДОПОЛНИТЕЛЬНЫЙ РЕЗИСТОР

FD3139

Tensión: Máx. 250V
500 NF

Resistencia: 1MΩ

N

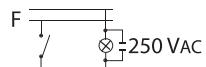

When using a switch with LED, the additional resistance stops LED lights from flickering when switched off, while saving energy. The additional resistance installed eliminates the capacitor's leakage currents that cause lights to flicker when the power is switched off.

Permite eliminar el parpadeo de las lámparas LED con un ahorro de energía en estado apagado, al utilizar un interruptor con iluminación. La resistencia adicional instalada en la cadena elimina las corrientes de fuga que cargan el condensador y llevan al parpadeo de las lámparas después de apagar la alimentación eléctrica.

Permet d'éliminer le clignotement des lampes LED pour une économie d'énergie. En mise sous tension, lous de l'utilisation d'un interrupteur d'éclaiage. La résistance supplémentaire installé dans la chaîne élimine les courants de fuite que produit le condensateur et qui conduit au clignotement des lampes une fois la mise hors tension de l'alimentation électrique.

UNIPOLAR SWITCH
INTERRUPTEUR UNIPOLAIRE
INTERRUPTORE UNIPOLARE
INTERRUPTOR UNIPOLAR
UNIPOLARSCHALTER
ОДНОПОЛЮСНЫЕ
ВЫКЛЮЧАТЕЛИ



FD16505
One-way SP switch/Interrupteur standard SP/Interruttore semplice/
Interruptor simple/SP Ausschalter/Выключатель SP 10A

FD16506
Two-way SP switch/Interrupteur va et vient SP/Commutadore/
Conmutador/SP Wechselschalter/Переключатель SP с 2-х мест.

FD16507
Intermediate switch/Interrupteur intermédiaire/Interruttore
incrociato/Cruzamiento/Intermediate switch/Переключатель с
3-х мест.

FD16605
Control one-way/Contrôle/Controllo a senso unico/Control/Einweg
Kontroll. 10 A 250 V~/Выключатель SP с индикацией режима
10 A

FD16557
One-way SP switch/Commutateur unidirectionnel/Interruttore SP
a una via/Interruptor simple/Einweg-SP-Schalter. 16A 250V~/
Выключатель SP 16 A

FD16559
Two-way SP switch/Interrupteur va et vient SP/Interruttore SP a
due vie/Conmutador/Zwei-Wege-SP-Schalter. 16 A 250 V~/
Переключатель с 2-х мест. 16 A

BIPOLAR SWITCH
INTERRUPTEUR BIPOLAIRE
INTERRUPTORE BIPOLARE
INTERRUPTOR BIPOLAR
BIPOLAR-SCHALTER
ДВУХПОЛЮСНЫЕ
ВЫКЛЮЧАТЕЛИ



FD16508
One-way DP switch / Interrupteur standard DP/Interruptor
bipolar simple One-way DP switch 10 A 250 V~/
Двухполюсный выключатель DP
10A 250B~

FD16558
One-way DP switch / Interrupteur va et vient DP/Interruptor
bipolar simple DP Ausschalter 16 A 250 V~/Двухполюсный
выключатель DP
16A 250B~

Le même mécanisme peut être utilisé pour une touche DP avec
lumière pour une touche de commande DP.

Lo stesso meccanismo può essere usato per un comando
bipolare con diffusore o per un comando bipolare DP.

El mismo mecanismo puede utilizarse para una tecla Bipolar
con difusor o para una tecla Bipolar de control.

Der gleiche Mechanismus kann für DP Schlüssel mit Licht oder
Kontrollschlüssel verwendet werden.

Эти механизмы могут быть использованы для DP
клавиш с подсветкой или контролирующих DP клавиш.

PUSH BUTTON MECHANISMS
MÉCANISMES BOUTON-POUSSOIR
MECCANISMI A PULSANTE
MECANISMOS PULSADORES
DRUCKTASTER MECHANISMEN
МЕХАНИЗМЫ КНОПОК



FD16516
Push-button
Bouton Poussoir
Pulsante
Pulsador
Drucktaster
10 A 250 V~
Кнопка
10A 250B~



FD16599
Push-button with temporized switch and diffuser
Timing 3 min. Max 500 W incandescent 230 V~
Interrupteur bouton poussoir avec minuterie et lumière
Synchronisation 3 min. Max 500 W à incandescence 230 V~
Pulsante con interruttore temporizzato e diffusore
Tempo minimo 3min. Max 500 W incandescente 230 V~
Pulsador con interruptor temporizador y difusor
Tiempo 3 min. Max 500 W incandescente 230 V~
Taster mit zeitlich einstellbaren Schalter und Diffusor 3 min.
Max 500 W Glühlampe 230V
Кнопка-выключатель с задержкой времени
выключения 3 мин.
10 A 230 B~
(Макс.500Ватт для ламп накали.)

UNIVERSAL SWITCHES

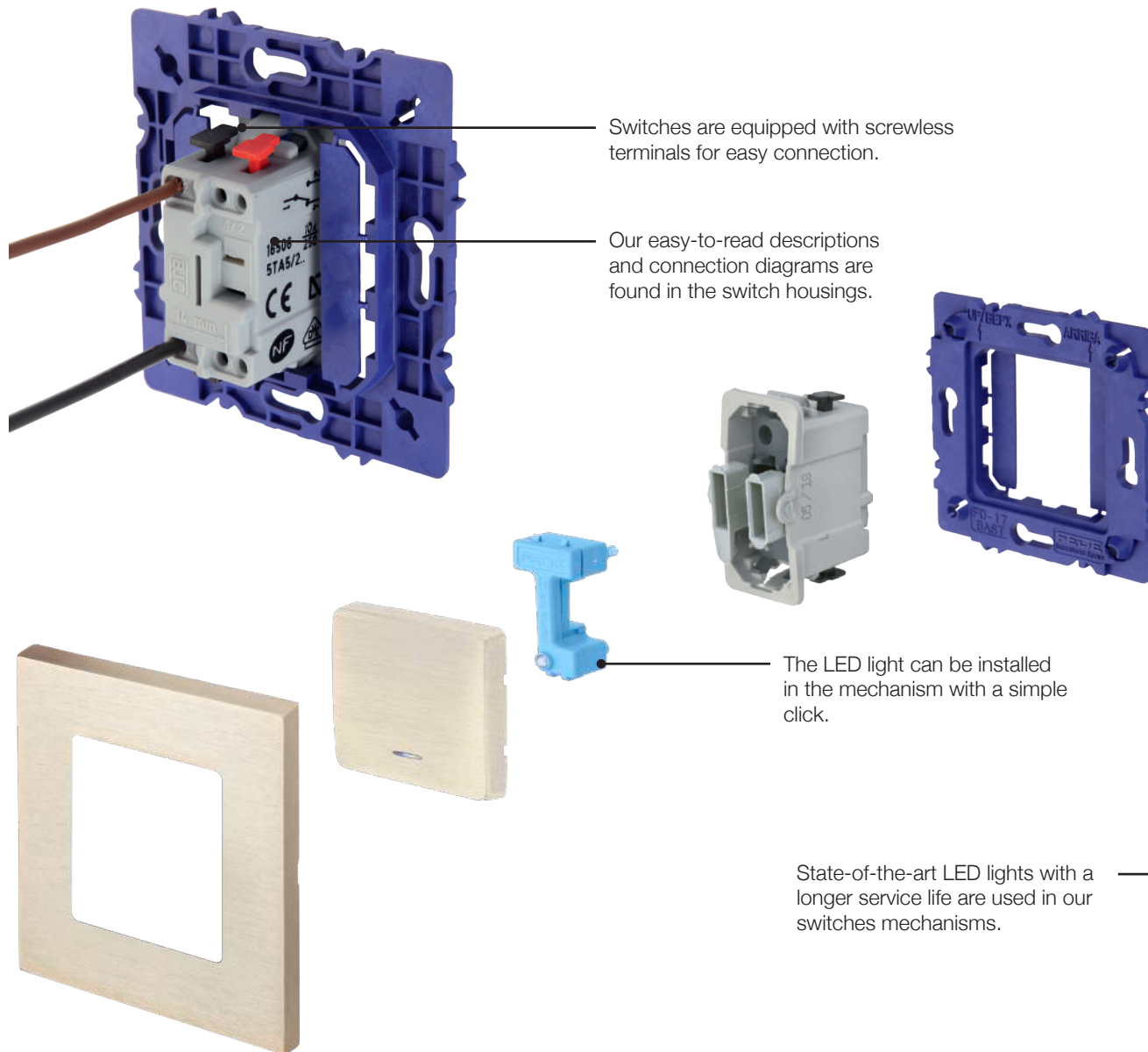

Switches are equipped with screwless terminals for easy connection.

Our easy-to-read descriptions and connection diagrams are found in the switch housings.

The LED light can be installed in the mechanism with a simple click.

State-of-the-art LED lights with a longer service life are used in our switches mechanisms.

The same type of mechanism is used for lighted and non-lighted switches.

LED lights are installed in the switch mechanism by applying slight pressure, connecting automatically.

If necessary, you can change your common switch into a lighted switch. To do this, simply install the LED light and replace the opaque key with the diffuser key.

Switch mechanisms are available in two options: 10 and 16 A.

10A & 16A

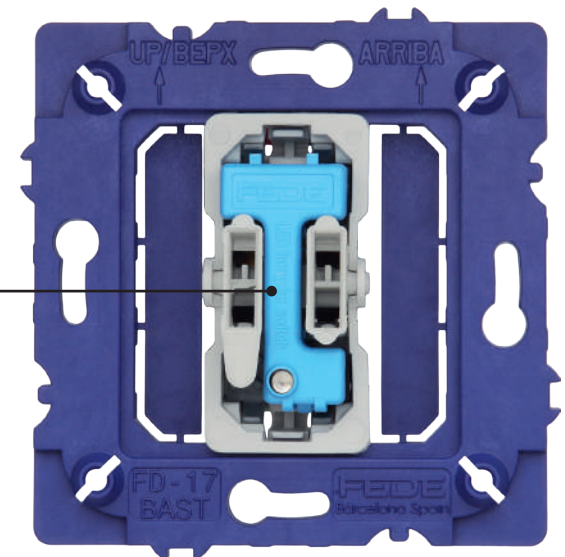

TOTAL SAFETY

Arrows with the corresponding inscriptions for the correct positioning of the mounting support (bracket).

High quality polyamide mounting support with fiberglass.

All anti-static parts of the mechanism are well protected.

The plastic covered metal keys provide excellent insulation of the surface when connecting the switch mechanism, offering maximum safety.

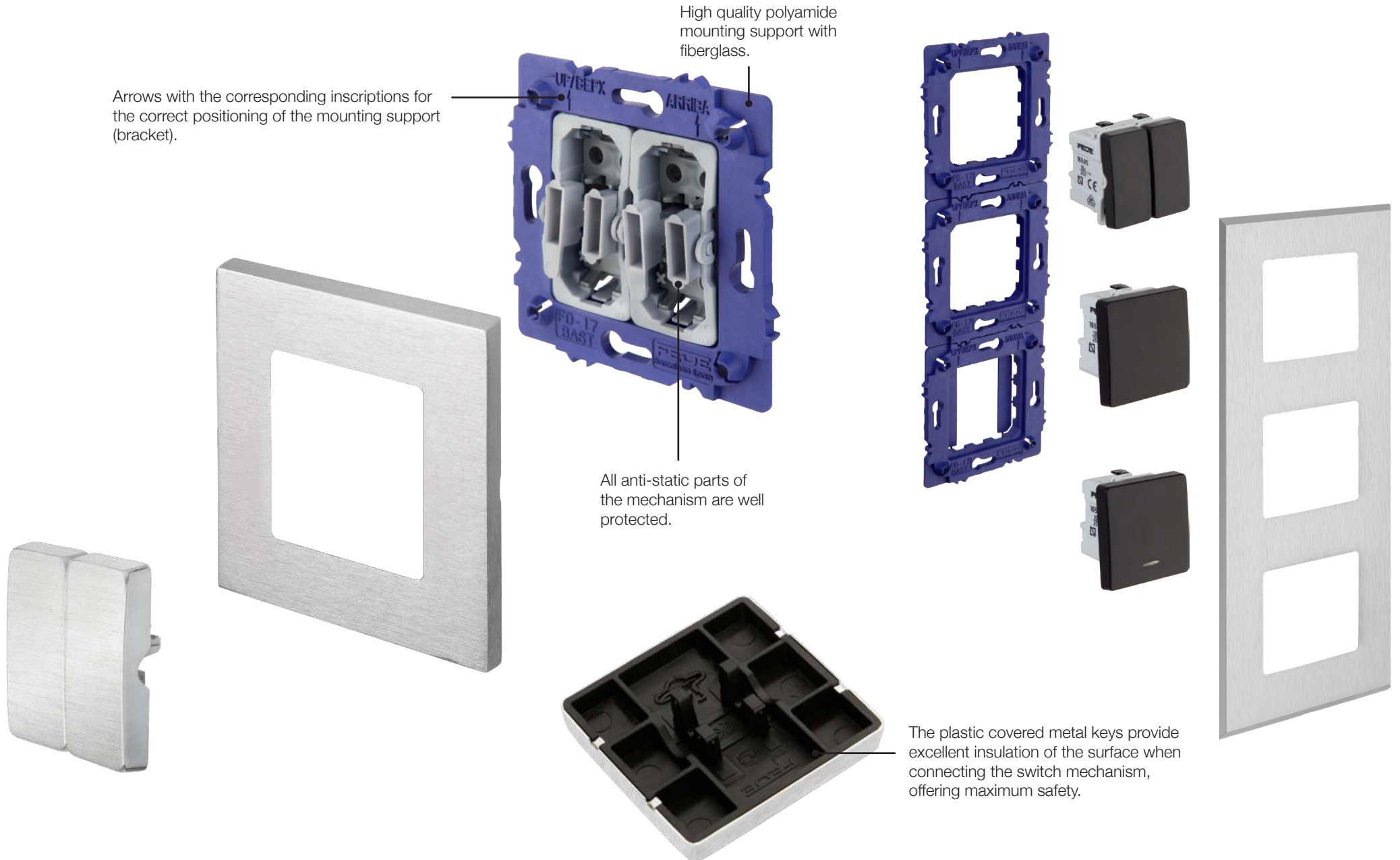

DEVICES ARE PROTECTED AGAINST HUMIDITY

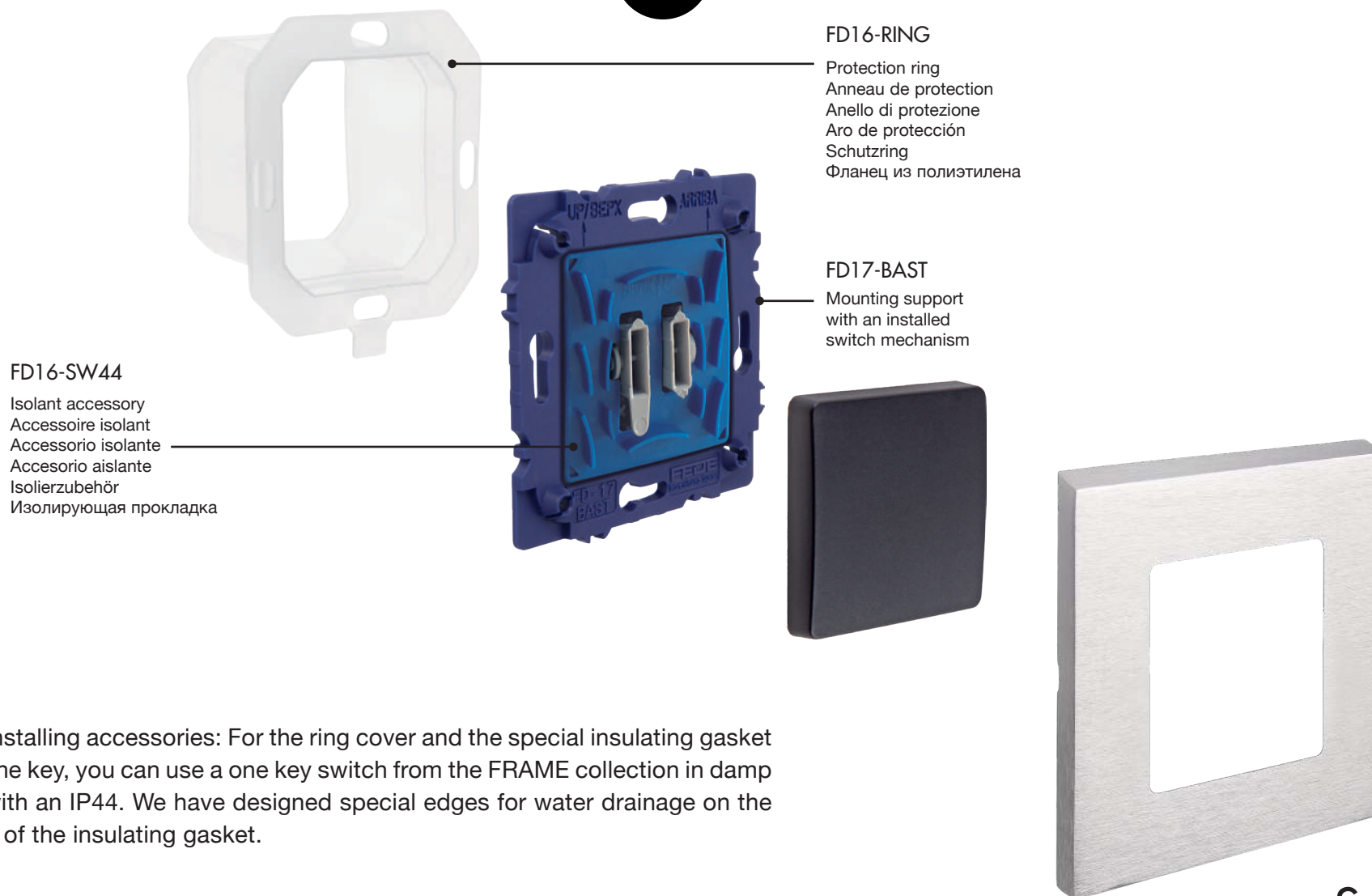

FD16-RING

Protection ring
Anneau de protection
Anello di protezione
Aro de protección
Schutzring
Фланец из полиэтилена

FD17-BAST

Mounting support
with an installed
switch mechanism

FD16-SW44

Isolant accessory
Accessoire isolant
Accessorio isolante
Accesorio aislante
Isolierzubehör
Изолирующая прокладка

When installing accessories: For the ring cover and the special insulating gasket below the key, you can use a one key switch from the FRAME collection in damp areas with an IP44. We have designed special edges for water drainage on the surface of the insulating gasket.

SoHo
collection



New LED Toggle Switch

And finally, we present the latest trend that is to turn on a light with a switch that incorporates a transparent toggle illuminated by LED.

How do we do it? Using the same standard switch mechanism. In this way, there is no need to make any additional changes to your project.

It's just great! A detail that does not go unnoticed.



Toggle Switch

All retro style fans, love toggle switches.

Our new toggle switches incorporate an innovative design and the latest technology to become objects of desire.

We have created the "it-switch". This invention of our **FEDE+** designers is incredibly MODERN & SOPHISTICATED!

TOGGLE SWITCH



FD02318BC-M



FD16505



FD04420P-M



FD17 - BAST

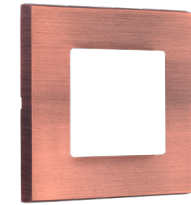

FD01701BC

MOUNTING EXAMPLE

①

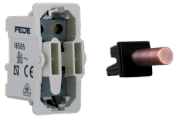

②



③

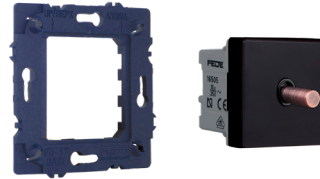

④

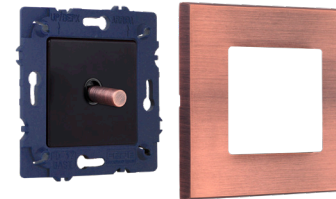

⑤



TOGGLE SWITCHES

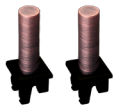

FD02318BC-M x 2



FD16505 x 2



FD04421P-M



FD17 - BAST

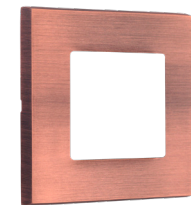

FD01701BC

MOUNTING EXAMPLE

①

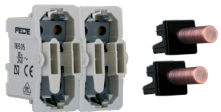

②



③



④

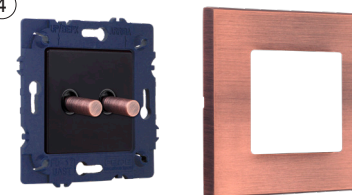

⑤

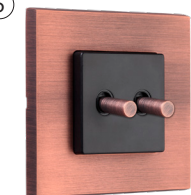

BRASS HANDLES / POIGNÉES EN LAITON / LEVETTE IN OTTONE / PALANCAS DE LATÓN / MESSINGGRIFFE / РУЧКИ ИЗ ЛАТУНИ

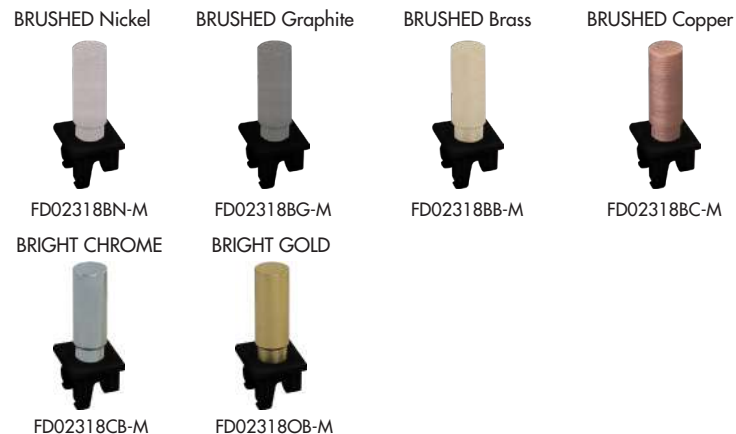

PLASTIC COVERS / COUVERTURES EN PLASTIQUE / NUOVE COVERS DI PLASTICA / TAPAS DE PLÁSTICO / KUNSTOFF OBERTEILEN / ПЛАСТИКОВЫЕ НАКЛАДКИ

WITHOUT DIFFUSER / SANS DIFFUSEUR / NESSUN DIFFUSORE / SIN DIFUSOR / OHNE DIFFUSOR / НАКЛАДКИ БЕЗ ДИФФУЗОРА

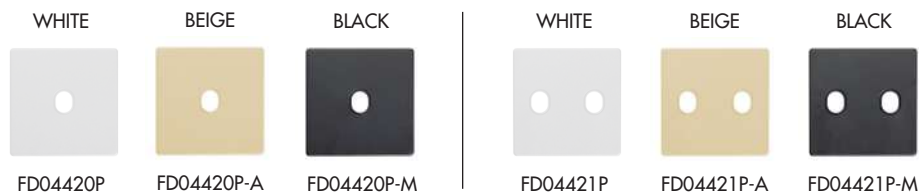

WITH DIFFUSER / AVEC LUMIERÈ / CON DIFFUSORE / CON DIFUSOR / MIT DIFFUSOR / НАКЛАДКИ С ДИФФУЗОРОМ



Please see switch & push-button mechanisms on page 15.

NEW LED HANDLES / NOUVELLES POIGNÉES TRANSPARENTES / NUOVE LEZIONI TRASPARENTE LED / NUEVAS PALANCAS TRANSPARENTES LED / NEUE LED TRANSPARENTEBEL / ПРОЗРАЧНЫЕ ПЛАСТИКОВЫЕ РУЧКИ

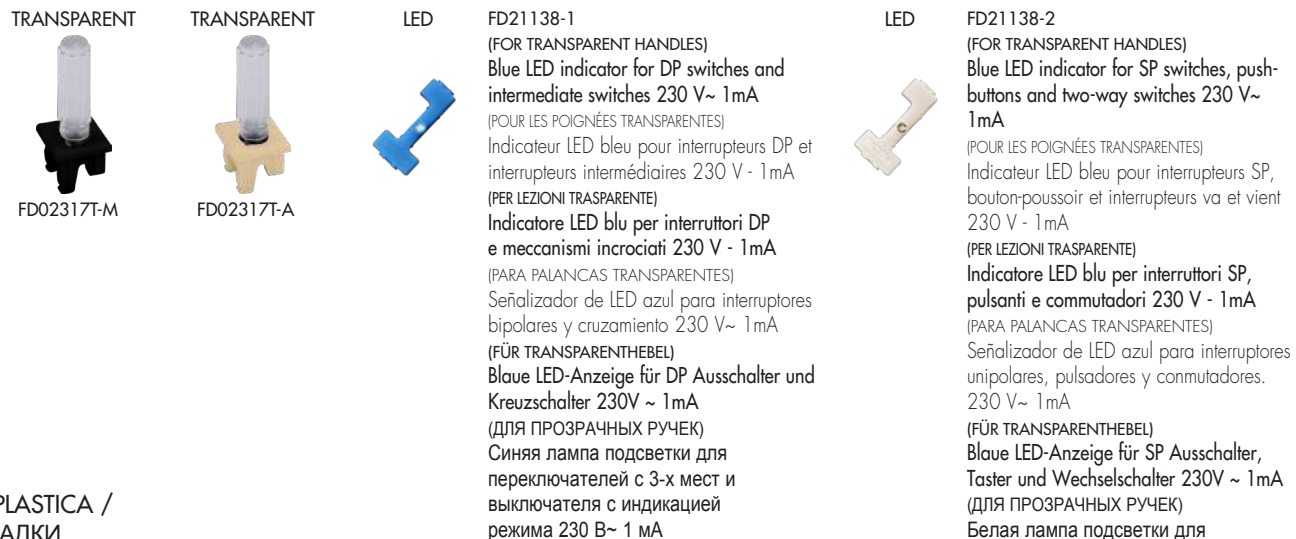

Pack of 20 units / Pack de 20 unidades / Упаковка: 20 шт.

NEW LED HANDLE / NOUVELLE POIGNEE LED / NUOVA LEVETTE LED / NUEVA PALANCA LED / NEUE LED HANDLE / СИГНАЛЬНЫЕ ЛАМПЫ

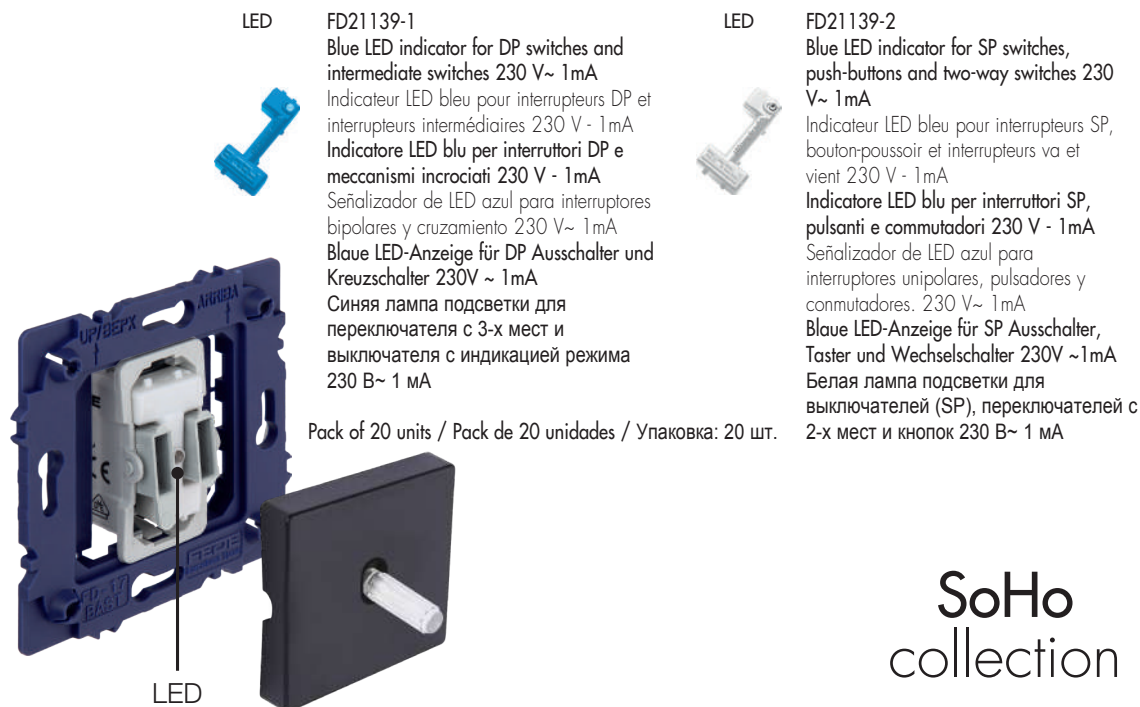

SoHo
collection

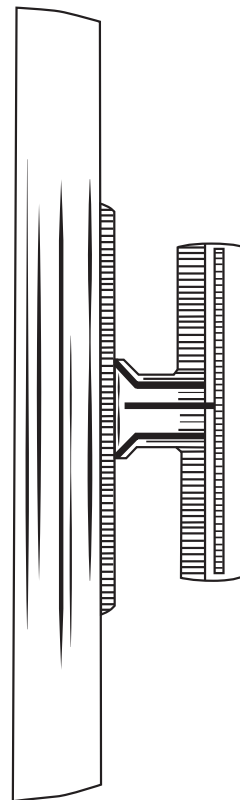

Rotary Switch

Rotary switches are a true embellishment from the collection, combining high switching capacity with a compact size.

The wide range of mechanisms with different connection schemes gives you the possibility to develop any kind of electrical project.

ROTARY SWITCH

The handles are made of high quality cast brass.



Central embellishment in two varieties: metal or plastic.

Switches with auxiliary lighting are equipped with state-of-the-art LED lights.

Our mechanisms occupy as little space as possible in the installation boxes. That way we can free up space for connections and facilitate installation. FEDE+ rotary switches are the most compact and powerful in the market.

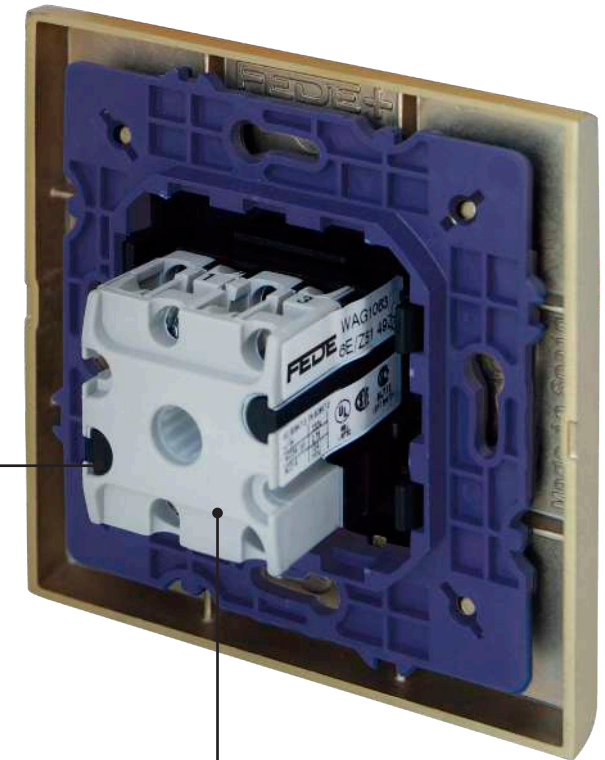

10A & 25A

The compact size does not affect power, as FEDE + switches have very high switching capacity, with two switch options for 10A and 25A.

SoHo
collection

PLASTIC/PLASTIQUE/PLASTICA/PLÁSTICO/
PLASTIK/ПЛАСТИКОВЫЕ НАКЛАДКИ

BRASS/LAITON/OTTONE/LATÓN/
MESSING/ЛАТУННЫЕ НАКЛАДКИ



10A 250V~
One-way rotary switch
Interrupteur rotatif standard
Interruttore rotativo standard
Interruptor rotativo simple
Aus-Drehschalter
Поворотный выключатель

WHITE	BEIGE	BLACK	BRUSHED Nickel	BRUSHED Graphite	BRUSHED Brass	BRUSHED Copper
FD03110	FD03110-A	FD03110-M	FD03110-BN	FD03110-BG	FD03110-BB	FD03110-BC
FD03111	FD03111-A	FD03111-M	FD03111-BN	FD03111-BG	FD03111-BB	FD03111-BC



10A 250V~
Two-way rotary switch
Interrupteur rotatif va et vient
Interruttore rotativo standard
Interruptor rotativo simple
Wechsel-Drehschalter
Поворотный выключатель с
2-х мест

WHITE	BEIGE	BLACK	BRUSHED Nickel	BRUSHED Graphite	BRUSHED Brass	BRUSHED Copper
FD03120	FD03120-A	FD03120-M	FD03120-BN	FD03120-BG	FD03120-BB	FD03120-BC
FD03121	FD03121-A	FD03121-M	FD03121-BN	FD03121-BG	FD03121-BB	FD03121-BC



10A 250V~
Intermediate rotary switch
Interrupteur rotatif intermédiaire
Invertitore di linea
Interruptor rotativo
de cruzamiento
Kreuzdrehschalter
Поворотный выключатель
с 3-х мест

WHITE	BEIGE	BLACK	BRUSHED Nickel	BRUSHED Graphite	BRUSHED Brass	BRUSHED Copper
FD03130	FD03130-A	FD03130-M	FD03130-BN	FD03130-BG	FD03130-BB	FD03130-BC
FD03131	FD03131-A	FD03131-M	FD03131-BN	FD03131-BG	FD03131-BB	FD03131-BC



10A 250V~
Double one-way SP switch
Interrupteur double va et vient SP
Interruttore rotativo doppio
Interruptor doble rotativo
Serienschalter
Сдвоенный поворотный
выключатель (аналог
двухклавишного
выключателя)

WHITE	BEIGE	BLACK	BRUSHED Nickel	BRUSHED Graphite	BRUSHED Brass	BRUSHED Copper
FD03140	FD03140-A	FD03140-M	FD03140-BN	FD03140-BG	FD03140-BB	FD03140-BC



25A 250V~
One-way rotary switch
Interrupteur rotatif standard
Interruttore rotativo standard
Interruptor rotativo simple
Drehbarer Ausschalter
Поворотный выключатель

PLASTIC/PLASTIQUE/ PLASTICA/PLÁSTICO/PLASTIK/
ПЛАСТИКОВЫЕ НАКЛАДКИ

WHITE	BEIGE	BLACK
FD03150	FD03150-A	FD03150-M

BRASS/LAITON/OTTONE/LATÓN/MESSING/
ЛАТУННЫЕ НАКЛАДКИ

BRUSHED Nickel	BRUSHED Graphite	BRUSHED Brass	BRUSHED Copper
FD03150-BN	FD03150-BG	FD03150-BB	FD03150-BC



25A 250V~
Double Pole rotary switch
Interrupteur rotatif à double pôle
Interruttore rotativo doppio
Interruptor doble rotativo
Doppelpoliger Drehschalter
Двухполюсный
поворотный выключатель

PLASTIC/PLASTIQUE/ PLASTICA/PLÁSTICO/PLASTIK/
ПЛАСТИКОВЫЕ НАКЛАДКИ

WHITE	BEIGE	BLACK
FD03160	FD03160-A	FD03160-M

BRASS/LAITON/OTTONE/LATÓN/MESSING/
ЛАТУННЫЕ НАКЛАДКИ

BRUSHED Nickel	BRUSHED Graphite	BRUSHED Brass	BRUSHED Copper
FD03160-BN	FD03160-BG	FD03160-BB	FD03160-BC

BRASS HANDLES FOR ROTARY SWITCHES
POIGNÉES EN LAITON POUR INTERRUPTEURS ROTATIFS
MANOVELLE IN OTTONE PER INTERRUPTORI ROTANTI
MANECILLAS DE LATÓN PARA INTERRUPTORES ROTATIVOS
MESSINGGRIFFE FÜR DREHSCHALTER
НОВЫЕ ЛАТУННЫЕ РУЧКИ ДЛЯ ПОВОРОТНЫХ ВЫКЛЮЧАТЕЛЕЙ

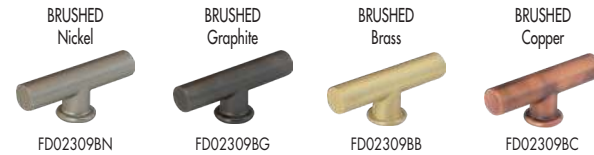

FD02309BN

FD02309BG

FD02309BB

FD02309BC

LED PILOT LAMPS/VOYANT LED/SEGNALETICA LED/SEÑALIZADOR LED/
LED-KONTROLLAMPEN/ЛАМПЫ ПОДСВЕТКИ ДЛЯ ПОВОРОТНЫХ ВЫКЛЮЧАТЕЛЕЙ



FD188LED220-1 White/Blanc/Bianco/Blanco/Weiss/Белый
FD188LED220-2 Blue/Bleu/Blu/Azul/Blau/Синий
FD188LED220-3 Amber/Ambre/Ambra/Ambar/Amber/Желтый

SoHo
collection



INFRARED LIGHT SWITCH

Replacing a regular wall switch, this unit automatically turns lights on when someone enters in a room. It increases energy savings by automatically turning lights off after only momentary occupancy. An integrated Light-Dependent-Resistor prevents lights from turning on when the room has adequate natural light. The combination of PIR and light-level detection technology provide excellent lighting control reliability. The slide-selector provided for conveniently switching light on/off manually or to enable PIR/CDS to operate automatically.

MULTIPLE FUNCTION CONTROLLER

This controller integrates multiple functions in one unit. It is designed as a replacement for the bathroom fan and light switch, and uses a microprocessor to control the fan delay-off operation. The Delay Timer function allows the fan to continue operating to complete the ventilation of the bathroom after use.

TOUCH SWITCHES / INTERRUPTEURS TACTILES / INTERRUITORI TATTILI / INTERRUPTORES TÁCTILES / BERÜHRUNGSSCHALTER / ЭЛЕКТРОННЫЕ СЕНСОРНЫЕ ВЫКЛЮЧАТЕЛИ

	WHITE	BEIGE	BLACK
Individual-light switch 600W. Pack of 1 unit Interrupteur Individuel 600W. Pack de 1 unité			
	FD28601	FD28601-A	FD28601-M
	Fixing support included	Support de fixation inclus	Bastidor incluido
Double-key-light switch 2x600W. Pack of 1 unit Interrupteur avec deux touches 2x600W. Pack de 1 unité			
	FD28602	FD28602-A	FD28602-M
	Fixing support included	Support de fixation inclus	Bastidor incluido
Bathroom light switch Lighting 800W. Ventilation 150W. Pack of 1 unit Interrupteur multifonction pour la salle de bain Lumière 800W. Ventilation 150W. Pack de 1 unité			
	FD28603	FD28603-A	FD28603-M
	Fixing support included	Support de fixation inclus	Bastidor incluido
Infrared light switch 800W. Pack of 1 unit Interrupteur avec détecteur de mouvement de présence 800W. Pack de 1 unité			
	FD28604	FD28604-A	FD28604-M
	Fixing support included	Support de fixation inclus	Bastidor incluido

SWITCH FOR BLINDS



SWITCHING MECHANISMS FOR BLINDS / MÉCANISMES ÉLECTRIQUES POUR LES STORES / MECCANISMI ELETTRICI PER PERSIANE / MECANISMOS CONMUTABLES PARA PERSIANAS / SCHALTMECHANISMEN FÜR JALOUSIE / МЕХАНИЗМЫ ДЛЯ УПРАВЛЕНИЯ ЖАЛЮЗИ

FD17665
10 A 250 V~



Double push-button for blinds. With electrical interlocking device.
Double bouton poussoir pour stores. Avec dispositif de verrouillage électrique.
Doppio bottone a pulsante per persiane. Con dispositivo di blocco elettrico.
Doble pulsador para persianas. Enclavamiento eléctrico.
Doppeldruckknopf für Jalousie. Mit elektrischen Verriegelungsmechanismus.
Механизм для управления жалюзи с электрической блокировкой.

FD17669
10 A 250 V~

Switch for blinds. With electrical and mechanical interlocking device.
Interrupteur pour stores. Avec dispositif de verrouillage électrique.
Interruttore per persiane. Con dispositivo di blocco elettrico.
Interruptor para persianas. Enclavamiento eléctrico y mecánico.
Schalter für Jalousie. Mit elektrischer und mechanischer Verriegelungsmechanismus.
Механизм для управления жалюзи с электромеханической блокировкой.

PLASTIC NARROW KEYS/TOUCHES ÉTROITES EN PLASTIQUE/PULSANTE STRETTO IN PLASTICA/ TECLAS ESTRECHAS DE PLÁSTIC/SCHMALE KUNSTSTOFFSCHLÜSSEL/ПЛАСТИКОВЫЕ КЛАВИШИ

WHITE



FD17769

BEIGE



FD17769-A

BLACK



FD17769-M

These mechanisms are provided with a security system that prevents the up and down signal being sent simultaneously.
Ces mécanismes ont un système de sécurité qui empêche le signal de vers le haut et vers le bas d'être envoyé simultanément.
Questi meccanismi sono dotati di un sistema di sicurezza che impedisce al segnale di scorrere in alto e in basso simultaneamente.
Estos mecanismos cuentan con un sistema de seguridad para evitar la llegada de los de arriba /abajo la señal de forma simultánea.
Diese Mechanismen sind mit einem Sicherheitssystem, damit verhindert wird das die Auf- und Abwärtssignale nicht gleichzeitig gesendet werden.
Mechanismen sind mit einem Sicherheitssystem, damit verhindert wird das die Auf- und Abwärtssignale nicht gleichzeitig gesendet werden.
Эти механизмы обеспечивают повышенную безопасность, благодаря тому, что обеспечивают возможность одновременной передачи сигналов "Вверх" и "Вниз".

BRASS KEYS/TOUCHES EN LAITON/PULSANT IN OTTONE/TECLAS DE LATÓN/METAL-SCHLÜSSEL/ЛАТУННЫЕ КЛАВИШИ

BRUSED Nickel



FD17769BN-A

BRUSHED Graphite



FD17769BG-A

BRUSED Brass



FD17769BB-A

BRUSHED Copper



FD17769BC-A

BRUSED Nickel



FD17769BN-M

BRUSHED Graphite



FD17769BG-M

BRUSED Brass



FD17769BB-M

BRUSHED Copper



FD17769BC-M

Touch Dimmer

Our touch dimmer is a smart and modern device, which significantly expands the ability to control lighting.



DIMMER / VARIATEUR / REGOLATORE / REGULADOR DE LUZ / DREHDIMMER/
ЭЛЕКТРОННЫЙ ДИММЕР С СЕНСОРНЫМ УПРАВЛЕНИЕМ

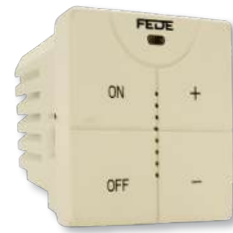

Compact touch Dimmer for all FEDE frames collections
Nouveau variateur tactile pour toutes les collections FEDE
Nuovo regolatore a tatto per tutte le collezioni FEDE
Regulador de luz táctil compacto para todos los marcos de FEDE
Tastdimmer für alle FEDE kollektionen
Компактный сенсорный диммер подходит для
установки во все рамки из коллекций FEDE

230V 50Hz / 600W

WHITE



FD28625

BEIGE



FD28625-A

BLACK



FD28625-M

Dimmer with touch controls
Resistive load: 600 W
Inductive load: 200 W
230 V \pm 10%, 50/60 Hz
Pack of 1 unit

SoHo
collection



Rotary Dimmer

At **FEDE+**, we have the best master metal craftsmen. The rotary hands of the dimmer are made of genuine brass with a hand-crafted finish.

A refined luxury detail for your decorative project. Your touch will not leave you indifferent!

DIMMER / VARIATEUR / REGOLATORE / REGULADOR DE LUZ / DREHDIMMER / ЭЛЕКТРОМЕХАНИЧЕСКИЙ ДИММЕР С ПЛАСТИКОВЫМИ НАКЛАДКОЙ И РУЧКОЙ



WHITE



FD16438

BEIGE



FD16438-A

BLACK



FD16438-M

Rotary dimmer for all FEDE collections
 Nouveau variateur pour toutes les collections FEDE
 Nuovo regolatore per tutte le collezioni FEDE
 Regulador de luz para todas las colecciones de FEDE
 Drehdimmer für alle FEDE kollektionen

16A / 750W

Электромеханический диммер

16A / 750 Вт,
 230 В ± 10%, 50/60 Гц

*В комплекте диммер оснащен пластиковой поворотной ручкой.
 При желании Вы можете заменить пластиковую ручку на латунную.

DIMMER WITH DECORATIVE BRASS COVER / VARIATEUR AVEC COUVERTURE EN LAITON / REGOLATORE DI LUCE CON COVERS IN OTTONE / REGULADOR DE LUZ CON TAPA DE LATÓN / NEUE DREHDIMMER MIT MESSINGABDECKUNGEN / ЭЛЕКТРОМЕХАНИЧЕСКИЙ ДИММЕР С ЛАТУННОЙ НАКЛАДКОЙ И ПЛАСТИКОВОЙ РУЧКОЙ



BRUSHED Nickel



FD16438BN-A

BRUSHED Graphite



FD16438BG-A

BRUSHED Brass



FD16438BB-A

BRUSHED Copper



FD16438BC-A

BRASS ROTARY HANDLES / POIGNÉES ROTATIVES EN LAITON / MANOPOLA ROTATIVA IN OTTONE / BOTÓN GIRATORIO DE LATÓN / MESSINGDREHGRIFFE / ПОВОРОТНЫЕ РУЧКИ ИЗ ЛАТУНИ



BRUSHED Nickel



FD04336BN

BRUSHED Graphite



FD04336BG

BRUSHED Brass



FD04336BB

BRUSHED Copper



FD04336BC

*To change plastic rotary handle for brass rotary handle, you just need to replace the plastic one and put another type from brass. Plastic handle is included with dimmer mechanism.

*Pour changer les poignées rotatives en plastique en poignée rotative en laiton, vous avez juste à remplacer celle en plastique pour celle en laiton. La poignée en plastique est incluse avec le mécanisme du variateur.

*Per sostituire le manopole in plastica con quelle in ottone, è sufficiente sostituire la plastica per l'ottone. La manopola in plastica è inclusa con il meccanismo dimmer.

*Para cambiar el botón giratorio de plástico por el botón giratorio de latón, basta con sustituir el de plástico colocando el de latón. El botón de plástico está incluido con el mecanismo del regulador de luz.

*Für den Wechsel von Kunststoff Drehgriff für Messingdrehgriff, müssen Sie nur Kunststoffdrehgriff mit einem anderen Messingtyp ersetzen. Kunststoffgriff ist beim Dimmer Mechanismus inbegriffen.

*Ручка из латуни для поворотного диммера. Данные ручки устанавливаются на механизмы диммеров FD16438

DIMMERS FOR PUSH BUTTONS



Designation	FD-LD100	FD-LD220	FD-LD440
Item number	V-4010020IB	V-4022010IB	V-4044020IB
Power	1-100W	1-200W	1-440W
Voltage	230V +/-10% 50/60 Hz	230V +/-10% 50/60 Hz	230V +/-10% 50/60 Hz
Max current	0,43A	0,87A	1,91A
For dimming of			
- Dimmable 230V LED	1-100W	1-200W	1-440W
- Dimmable LED driver for phase control	1-100W	1-200W	1-440W
- Dimmable CFLs	1-100W	1-200W	1-440W
- 230V halogen lamps	1-100W	1-200W	1-440W
Electronic transformers	1-100W	1-200W	1-440W
Incandescent light	1-100W	1-200W	1-440W
Has adjustable minimum dimming level	Yes	Yes	Yes
Memorises the last set brightness, even after power failure	Yes	Yes	Yes
With motion detection / twilight relay / timer	Yes	Yes	Yes
Is controlled up to 5 reactive toggle switches	Yes	Yes	Yes
With soft start	Yes	Yes	Yes
Dimension	Ø56 H22 mm	Ø56 H22 mm	Ø56 H22 mm

Wider dimming range	Wider dimming range, starts already at 1 W
Excellent test ratings	0-100% dimming
Adjustable min. dimming level	Highest ratings in tests of 25 leading brands of 230 V LED lamps. Average rating 4,7 points out of 5. 15 lamps scoring 5 out of 5. Different minimum settings possible for LED lamps and CFL.

DIMMERS FOR PUSH BUTTONS



FD16516
10A 250V~
Push-button
Pousse-bouton
Pulsante
Pulsador
Drucktaster
Кнопка



FD16599
Push-button with temporized switch and diffuser. Timing 3 min. Max 500W incandescent 230V~
Bouton-poussoir avec interrupteur et diffuseur temporisé. Synchronisation 3 min. Max 500Wà incandescence 230V~
Pulsante con interruttore temporizzato e diffusore. Tempo minimo 3min.
Max 500W incandescente 230 V~
Pulsador con interruptor temporizador y difusor. Tiempo 3 min. Max 500W incandescente 230V~
Taster mit zeitlich einstellbaren Schalter und Diffusor 3 min. Max 500W Glühlampe 230V
Кнопка-выключатель с задержкой времени выключения 3 мин.

PUSH BUTTON MECHANISMS
MÉCANISMES BOUTON-POUSSOIR
MECCANISMI A PULSANTE
MECANISMOS PULSADORES
DRUCKTASTER MECHANISMEN
МЕХАНИЗМЫ КНОПОК



FD-LD220
Dimmer for LED lamp
Power: 200W
230V 50/60 Hz
Installed in the mounting box
behind the push button.
Dimensions: 56 x 22 mm
Units: 1



FD-LD440
Dimmer for LED lamp
Power: 440W
230V 50/60 Hz
Installed in the mounting box
behind the push button.
Dimensions: 56 x 22 mm
Units: 1



FD-LD220WCM
LED Dimmer with Bluetooth®
Power: 200W
230V 50/60 Hz
Installed in the mounting box
behind the push button.
Dimensions: 50 x 15.5 mm
Units: 1



FD-LD200KRON
Dimmer for 2-channel LED lamp
Power: 2x100W
230V 50/60 Hz
Installed in the mounting box
behind the push button.
Dimensions: 57 x 21 mm
Units: 1



DIMMERS FOR PUSH BUTTONS

FD-LD100, FD-LD220 and FD-LD440

Universal push dimmers FD-LD100, FD-LD220 and FD-LD440

Universal LED-dimmers for wallbox installation that starts at 1W

A common problem - when dimming LED lamps and CFL lamps - is that conventional dimmers usually require a high minimum load of 50W, 35W or 20W, while low energy light lamps and LED lamps have a power range from 1W up to 20W. For dimming of these low energy lamps dimmers that can operate from 1W and up are required. The series of universal push dimmers starts already at 1W for dimming of both lowpower lamps as well as electronic transformers, dimmable LED-drivers and incandescent lamps.

Adjustable minimum dimming level

Depending on the type of load that is connected to the dimmer, the dimmer's lowest dimming level can be adjusted to fit the load in question. The dimming characteristic is distinguished between different types of loads. This feature is perfect for use when there is mixed loads of different lamptypes including dimmable halogen and incandescent lights. It is also very handy if the user at some future date decides to switch from incandescent to 230 VAC dimmable LEDs. Then you need only adjust the lowest dimming level to the new load, instead of buying a new dimmer.

Memory function

Equipped with memory function that also remains after power failure.

BLUETOOTH SYSTEM

PROFESSIONAL LIGHT CONTROL

Wireless control with CASAMBI



- Complete control system
- Wireless sync of all lighting
- With integrated control for 1 to 10V & 
- Presence sensors, astro- and timer functions
- Easily controlled with app and/or button

Wireless control with CASAMBI

The system is based on the standardised Bluetooth protocol, which is integrated in the majority of today's smart phones and tablets. With app support for Android and Apple iOS, you can easily control your lighting, with complete dimming options through your smart phone. The system enables you to, for instance, control all light sources, downlights, LED strings, wall sockets, garage doors, Venetian blinds and much more. You can of course also control the system with a classic non-locking button.

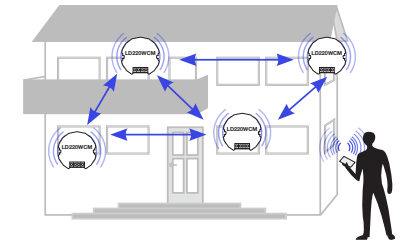

By using MESH network technology, you only need to be within reach (usually 30 metres) of just one unit in order to control all units.

THE APP

Dimming using the app

You get simple, intuitive dim ring and light / extinguish function through the free Casambi app.

Astro-feature and timer control

The astro-feature means that your lighting is activated by the sunrise and sunset. The astro-feature and timer controls are set through the app. The settings are thereafter stored in the dimmer memory, and work on the basis of the dimmer's internal clock, and function completely independently.

Grouping and scenarios

Group your light sources through the app and dim/control them simultaneously. You can of course also set different scenarios in separate rooms. For instance, if you wish to turn off all the light sources, or dim only a certain set of light sources in a particular room. Everything is possible with the dimmer and the app. Only your imagination is the limit!

Unlimited reach

By using MESH network technology, you only need to be within reach (usually 30 meters) of just one unit in order to control all of them. Communication takes place automatically between units within reach. The Bluetooth dimmer FDLD220WCM is placed in a box and provides a natural dispersion of the network in the course of the installation.

No router

The Bluetooth system does not require any external router, as all communication is saved in the Bluetooth cloud. This is cost effective, provides quick communication, and is very practical.

Constantly updated units

The software in your units can be easily updated by connecting to the network through your smart phone/tablet. This provides the units with the latest features and updates. The units update each other automatically when new firmware is uploaded.

Control options

The app allows you to take pictures of your rooms, and then activate the light by placing your finger on a lamp. Unbelievably simple!

Access and sharing settings

The first time your units are used, they are paired with a master unit (smart phone or tablet). The network or unit can thereafter be shared with other units. You can easily password-protect your network or leave it open for access. The internal communication between the dimmers is well protected through asymmetric keys or an encrypted schedule. You can also share the settings with your loved ones within the household in order for them to gain complete access to all the light control options. Simple and user-friendly.

Scalable system

The FDLD220WCM is included in the wireless system and can be integrated with products such as the FDSSW60WCM. Read more about each product on the next page.

Gateway feature

By enabling gateway functionality on an existing iOS or Android device, you will be able to access your home while at work, at the beach or if you just want to support an existing customer with his/her installation. You do not need to buy an additional router, rather it is sufficient to have one unit in place that runs iOS or Android, such as a tablet etc.



BLUETOOTH SYSTEM



System parts



FDLD220WCM

Bluetooth dimmer

The FDLD220WCM is a universal, back edge-controlled phase dimmer, which dims between 0 and 200 VA. The dimmer, like the other products, consists of an astro-timer as well as the option of connecting a non-locking press button. The dimmer is extremely small, which means that there is plenty of space inside the box. It is also possible to deactivate the dimmer feature in order to operate non-dimmable loads.



FDCM10WCM

The control device

The FDCM10WCM is a control device which converts the Bluetooth signal to between 0/1 and 10 V. This can be retro-fitted in the current system or, for instance, when you wish to install a more powerful dimmer in the system. In the DALI mode, there is support for, for instance broadcast, colour control and light temperature.



FDPWM4WCM

Control device for colour

The FDPWM4WCM is a control device that controls the colour of the light fittings and LED strings that are intended for RGBW control. RGBW is used, among other places, at restaurants, churches, and play areas to set the correct mood and draw interest. FDPWM4WCM can handle 144W/24Vdc and 72W/12Vdc.



FDSSW60WCM

The digital actuator

Our Swedish-developed actuators now coexist with a unique product. With the SoftSwitcher FDSSW60WCM and, with its 32 set settings for loads, it is possible to control/operate all the LED fittings and strings available in the market. FDSSW60WCM is a digital actuator that has enabled a compact design with its 60W.

Practical system solutions



Living room

Downlights, LED strings and light sources are controlled by the Bluetooth actuator, and become part of the system. Connect the non-locking press button, and specify in the app the action that you want to perform



The app

Large windows with daylight in daytime, need a matching scenario. The Astro-timer and schedule settings ensure that guests always enjoy the correct lighting.



Shops, restaurants, and public environments

Control small and large lighting groups. The system is complete with dimmers from 0 to 2000 VA for LED lights. The installation is quick as unnecessary wiring and complicated programming are not required. The risk of unintended expenses also reduces. If you want to connect more lighting later, the integration will be quick and smooth.



The app

Light fittings and light sources with scenarios and animations get the customers and employees in the right mood. You create a vivid environment.

Outdoor lighting

Connect wall lights, bollards and deck lights to the Bluetooth system, and have the same control outdoors, as indoors. Wireless synchronisation simplifies wiring.



The app

The astro-timer, scenarios and animations impress the neighbours, and frighten off uninvited guests.

□ SSW60WCM

● LDD220WCM

◆ Mpress

■ Xpress

● PWM4WCM

◆ CM10WCM

NIGHT LIGHT INDICATOR

*ITEMS' REAL SIZE ARE SHOWN IN THE IMAGES

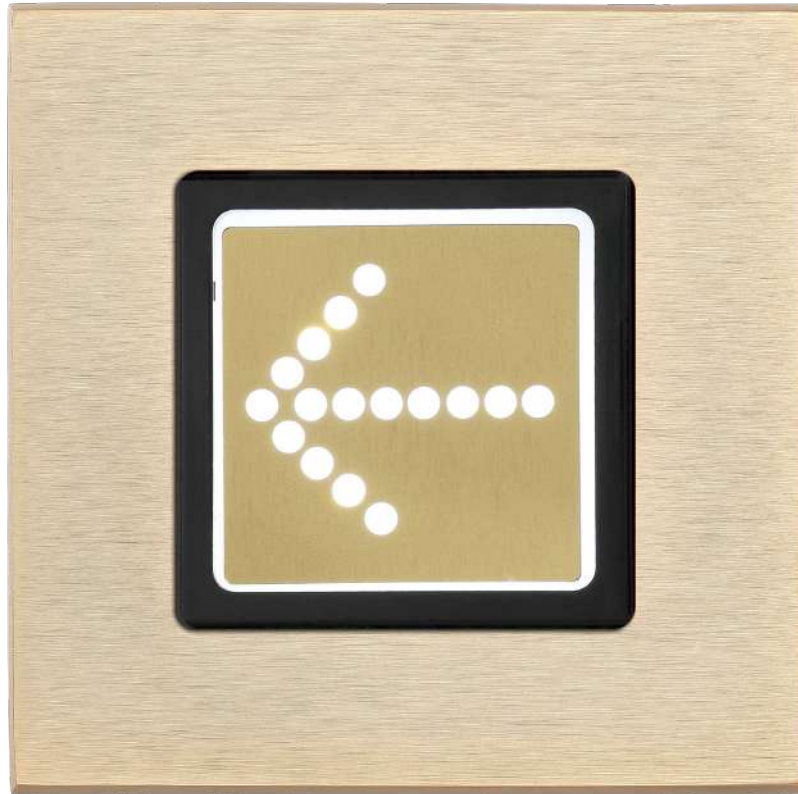

Our NIGHT LIGHT INDICATOR is particularly designed for directional guiding in dim environments, they can be situated in rooms, stairways or at any required location in buildings. Two separate styles are provided for the Night Light Indicator.

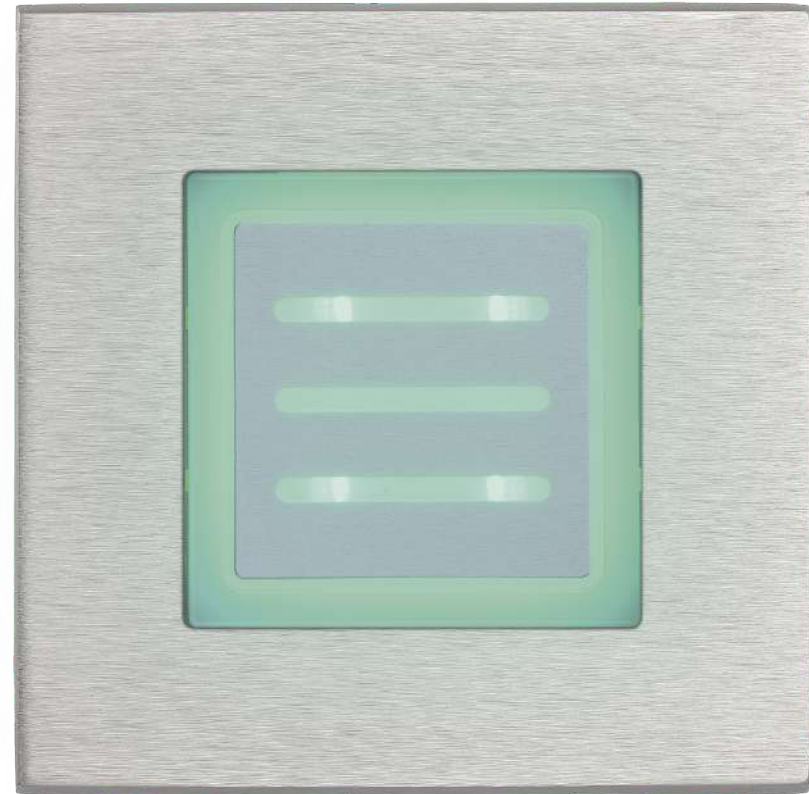

1. FD28606 White-Red colored LED selectable
2. FD28607 RGB color changeable LED

Electronic devices with minimal power consumption. 17 styles of self-adhesive front-panel stickers are available optionally.

NIGHT LIGHT INDICATOR / NOUVEAUX VOYANTS / NUEVOS SEÑALIZADORES LUMINOSOS / СВЕТОДИОДНЫЕ СВЕТИЛЬНИКИ-ИНДИКАТОРЫ

Night Light Indicator White-Red colored LED selectable for all FEDE Collections
Fixing support included
Pack of 1 unit

Voyants LED disponible en blanc et rouge pour toutes les collections
Support de fixation inclus
Pack de 1 unité

Señalizador luminoso LED disponible en blanco y rojo para todas las colecciones FEDE.
Bastidor incluido
Pack de 1 unidad

Светодиодный светильник-индикатор (с переключателем цвета "Красный/Белый")
Механизм поставляется в к-те с суппортом
Упаковка: 1 шт.

FD28606

RED & WHITE
ROJO y BLANCO
ROUGE ET BLANC



Night Light Indicator RGB color changeable LED for all FEDE Collections
Fixing support included
Pack of 1 unit

Voyants LED de couleur RGB pour toutes les collections FEDE.
Support de fixation inclus
Pack de 1 unité

Señalizador luminoso LED de color RGB para todas las colecciones FEDE.
Bastidor incluido
Pack de 1 unidad

Светодиодный светильник-индикатор с RGB-контроллером для изменения цвета и яркости свечения)
Механизм поставляется в к-те с суппортом
Упаковка: 1 шт.

FD28607

RGB
RGB



STICKERS / ETIQUETTES / ETIQUETAS / НАКЛЕЙКИ

FINISHES AVAILABLE Stickers for Night Light Indicator Pack of 1 unit

ACABADOS DISPONIBLES
FINITIONS DISPONIBLES
ДОСТУПНЫЕ ВАРИАНТЫ ЦВЕТОВ

ALUMINIUM / ALUMINIUM / ALUMINIO / АЛЮМИНИЙ
FD28608-A, FD28609-A, FD28620-A, FD28621-A,
FD28622-A, FD28623-A

GOLD / OR / ORO / ЗОЛОТО
FD28608-G, FD28609-G, FD28620-G, FD28621-G,
FD28622-G, FD28623-G

Etiquettes pour les voyants. Pack de 1 unité
Etiquetas para el Señalizador luminoso. Pack de 1 unidad

*For Aluminium (A), gold (G) and Black (B) finish for reference FD28624, please add A, G or B at the end.

*Pour l'Aluminium (A), l'or (G) et le noir (B) dans les finitions pour la référence FD28624, veuillez, s'il-vous plaît, ajouter un A, G ou B à la fin de référence.

*Para Aluminio (A), Oro (G) y Negro (B) en los acabados FD28624, por favor añadir una A, G o B al final de la referencia.

*Для выбора Алюминия (А), золота (G) и черного (B) цвета (только для наклейки FD28624) необходимо добавить соответствующую букву к концу кода, например: FD28624-A, FD28624-G, FD28624-B.

FD28624-A

FD28624-G

FD28624-B



FD28608 FD28609 FD28610 FD28611 FD28612 FD28613 FD28614 FD28615 FD28616 FD28617 FD28618 FD28619 FD28620 FD28621 FD28622 FD28623 FD28624

For customized stickers, please contact us.

Pour personnaliser les etiquettes, veuillez nous contacter.

Para personalizar las etiquetas, por favor contactáncos.

SoHo
collection

NEW USB CHARGER

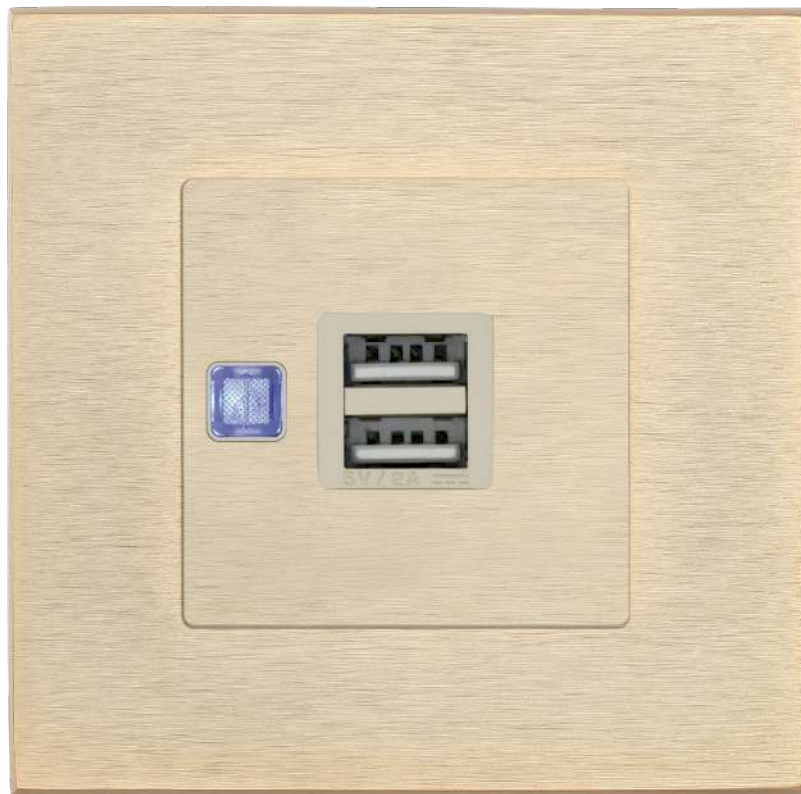

This product (hereinafter referred to as FD-212USB) is designed to follow users needs to do a combination of elasticity after once installed, can completely replace the existing function of external chargers, and save the cost compared to the external charger. FD-212USB can convert general AC power supply into USB power very easy, Charge electricity quickly and save time.



5VDC - 2A

MECHANISMS WITH FRONT PLASTIC COVERS
 MÉCANISMES AVEC COUVERCLES EN PLASTIQUE
 MECCANISMI CON COVERS DI PLASTICA
 MECANISMOS CON TAPAS DE PLÁSTICO
 MESSINGKAPPE MECHANISMUS
 МЕХАНИЗМЫ С ПЛАСТИКОВЫМИ НАКЛАДКАМИ

WHITE



FD-212USB

BEIGE



FD-212USB-A

BLACK



FD-212USB-M

MECHANISMS WITH BRASS COVERS / MÉCANISME AVEC COUVERCLES EN LAITON / MECCANISMI CON COVERS IN OTTONE / MECANISMOS CON TAPAS DE LATÓN / MESSINGABDECKUNGEN / МЕХАНИЗМЫ С ЛАТУННЫМИ НАКЛАДКАМИ

BRUSHED Nickel



FD-212USBBN-A

BRUSHED Graphite



FD-212USBBG-A

BRUSHED Brass



FD-212USBBB-A

BRUSHED Copper



FD-212USBBC-A

USB CHARGER DOUBLE OUTPUT PORT / CARGADOR USB DOBLE PUERTO DE SALIDA / ЗАРЯДНОЕ УСТРОЙСТВО С ДВУМЯ USB ПОРТАМИ

USB charger can charge mobile phones and Smartphones, MP3 players, MP4s and iPods, tablets and iPads, digital cameras, Sat Navs and game consoles.
High performance, functionality, reliability and quality.

El cargador USB puede cargar teléfonos móviles y Smartphones, reproductores MP3, MP4s y iPods, Tablets y iPads, cámaras digitales, navegadores por satélite y video consolas.
Alto rendimiento, funcionalidad, fiabilidad y calidad.

Le chargeur USB peut recharger les téléphones mobiles, les Smartphones, lecteurs MP3, MP4, iPods, tablettes et iPads, appareils photo digitales, tablettes tactiles et les consoles de jeux.
Haute performance, fonctionnalité, fiabilité et qualité.

USB Ladegerät für Mobiltelefone, Smartphones, MP3-Player, MP4s, iPods, Tablets und iPads, Digitalkameras, Navigationsgeräte und Spielekonsolen
Hohe Leistung, Funktionalität, Zuverlässigkeit und Qualität.

Il caricatore USB può caricare cellulari e Smartphones, players MP3, MP4 e iPods, Tablets e iPads, fotocamere digitali, navigatori satellitari e video consoles.
Alta performance, funzionalità, affidabilità e qualità.

SPECIFICATIONS / CARACTÉRISTIQUES / SPECIFICHE / ESPECIFICACIONES / TECHNISCHE DATEN / ТЕХНИЧЕСКИЕ ХАРАКТЕРИСТИКИ

INPUT: 110~230VAC, 50~60HZ, 0.3A

OUTPUT: 5VDC, 2A TOTALLY

PORT1 ONLY OR PORT1 + PORT2

STANDBY: BLUE 

CHARGING: RED 

CHARGED: GREEN 

REGULATION: USB DCP, BC 1.2 STANDARD

AUTO DETECTION OF USB D+/D- LINE VOLTAGE

INTELLIGENT CHARGE-CURRENT CONTROL ON PORT 1, MAX. 2A

STORAGE TEMPERATURE: -10 +40°C

USAGE TEMPERATURE: -10 +40°C

HUMIDITY: 0-60% NON-CONDENSING

ENTRÉE: 110 ~ 230VAC, 50 ~ 60HZ, 0.3A

SORTIE: 5VDC, 2A TOTAL

PORT 1 UNIQUEMENT OU LE PORT 1 + PORT 2 LED ÉTAT

VEILLE: BLEU 

CHARGE: ROUGE 

CHARGÉ: VERT 

RÈGLEMENT: USB DCP, BC 1.2 STANDARD

AUTO DÉTECTION D'USB D+/ D- VOLTAGE

CONTRÔLE INTELLIGENT CHARGE COURANT SUR LE PORT 1, MAX. 2A

TEMPÉRATURE DE STOCKAGE : -10 +40°C

UTILISATION TEMPÉRATURE: -10 +40°C

HUMIDITÉ: 0-60% SANS CONDENSATION

INPUT: 110 ~ 230VAC, 50 ~ 60HZ, 0.3A

OUTPUT: 5VDC, 2A TOTALE

PORT 1 SOLO O PORT 1 + PORT 2

STANDBY: BLEU 

IN CARICA: ROUGE 

CARICO: VERT 

REGOLAZIONE: USB DCP, BC 1.2 STANDARD

AUTORICONOSCIMENTO DI USB D+/ D- VOLTAGE

CONTROLLO INTELLIGENTE DI RICARICA CORRENTE SU PORT 1, MAX. 2A

TEMPERATURA DI STORAGE : -10 +40°C

TEMPERATURE DI UTILIZZO: -10 +40°C

UMIDITÀ: 0-60% SENZA CONDENSA

ENTRADA: 110~230V, 50~60HZ, 0.3A

SALIDA: 5VDC, 2A TOTAL

PUERTO1 SÓLO O PUERTO1 + PUERTO2 STATUS LED

ENCENDIDO: AZUL 

CARGANDO: ROJO 

CARGADO: VERDE 

REGULACIÓN: USB DCP, BC 1.2 ÉSTANDARD

AUTO DETECCIÓN DEL USB D+/D- VOLTAJE DE LA LÍNEA

CONTROL DEL CAGADOR INTELIGENTE EN PUERTO1, MAX. 2A

TEMPERATURA DE ALMACENAMIENTO: -10 +40°C

TEMPERATURA DE USO: -10 +40°C

HUMEDAD: 0-60% SIN CONDENSACIÓN

EINGANG: 110 ~ 230VAC, 50 ~ 60HZ, 0.3A

AUSGANG: 5 V DC, 2A TOTAL

PORT 1 NUR ODER PORT 1 + 2-PORT-STATUS-LED

STANDBY: BLAU 

LADE: ROT 

GELADEN : GRÜN 

REGELUNG: USB DCP, BC 1.2 STANDARD

AUTOMATISCHE ERKENNUNG VON USB D + / D- LINE VOLTAGE

INTELLIGENTE LADESTROMSTEUERUNG AN PORT 1, MAX. 2A

LAGERTEMPORATUR: -10 BIS +40°C

EINSATZTEMPORATUR: -10 BIS +40°C

LUFTFEUCHTIGKEIT: 0-60% NICHT KONDENSIEREND

ВХОД: 110~230В, 50~60 Гц, 0,3А

ВЫХОД: 5В, 2А

ТОЛЬКО ПОРТ 1 ИЛИ ПОРТ 1 + ПОРТ 2 ((ИНДИКАТОР СОСТОЯНИЯ)

РЕЖИМ ОЖИДАНИЯ СИНИЙ 

РЕЖИМ ЗАРЯДКИ КРАСНЫЙ 

РЕЖИМ ЗАРЯЖЕН ЗЕЛЕНый 

СООТВЕТСТВИЕ СТАНДАРТАМ: USB DCP, BC 1.2 СТАНДАРТ

АВТОМАТИЧЕСКОЕ РАСПОЗНАВАНИЕ USB УСТРОЙСТВ D+/D-

СЕЛЕКТИВНЫЙ КОНТРОЛЬ ЗАРЯДКИ УСТРОЙСТВ ЧЕРЕЗ ПОРТ 1,

МАКС. 2А

ТЕМПЕРАТУРА ХРАНЕНИЯ: -10 +40°C

ТЕМПЕРАТУРА Э КСПЛУАТАЦИИ: -10+40°C

ВЛАЖНОСТЬ: 0-60%



NEW HOTEL CARD SWITCH

Our new hotel card mechanism offers a refined look thanks to its exclusive brass coating. Exquisite finishes for those lovers of unique details that benefit from the latest technology in LED signalling and a maximum to accept cards of different sizes, ranging from 0.7mm to 1.8mm. It supports all frames of the **FEDE** collections and is installed in a standard European box (60mm), just as the rest of mechanisms shown in this catalogue.

NEW HOTEL CARD SWITCH



SoHo
collection

FD17-BAST

FD16516

FD21139-2

FD04341BB

FD-4342IT
INTERNAL BUTTON
BOUTON INTERIOR
BOTÓN INTERNO
ВНУТРЕННЯЯ КЛАВИША

FD04340-A

Products description:

- Nominal voltage 230VAC, 10A.
- LED color- Blue
- Cables: rigid/flexible/stranded cables with section of 1.5mm²
- Operating ambient temperature from 5 to 35 °C
- Cards thickness min: 0.7 mm - max 1.8 mm
- Degree of protection IP20/IK04

PLASTIC FRONT COVERS
TAPAS DE PLÁSTICO
ПЛАСТИКОВЫЕ НАКЛАДКИ ДЛЯ
КАРТЧНЫХ ВЫКЛЮЧАТЕЛЕЙ

CORD OPERATED PUSH-BUTTON
PULSADOR TIRADOR
МЕХАНИЗМ СИГНАЛЬНОГО
ВЫКЛЮЧАТЕЛЯ СО ШНУРОМ 10 A 250 V ~

WHITE	BEIGE	WHITE	BEIGE	BLACK
FD04340	FD04340-A	FD16021	FD16021-A	FD16021-M

FRONT PARTS WITH COVERS / TAPAS EN LATÓN / ЛАТУННЫЕ НАКЛАДКИ ДЛЯ КАРТЧНЫХ ВЫКЛЮЧАТЕЛЕЙ

BRUSHED Nickel		BRUSHED Graphite		BRUSHED Brass		BRIGHT Copper	
FD04341BN	FD04341BN-A	FD04341BG	FD04341BG-A	FD04341BB	FD04341BB-A	FD04341BC	FD04341BC-A

IN-WALL Bluetooth[®] AUDIO RECEIVER

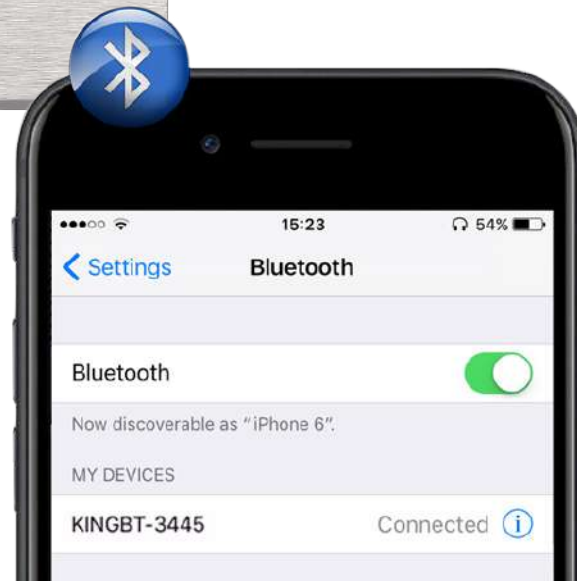
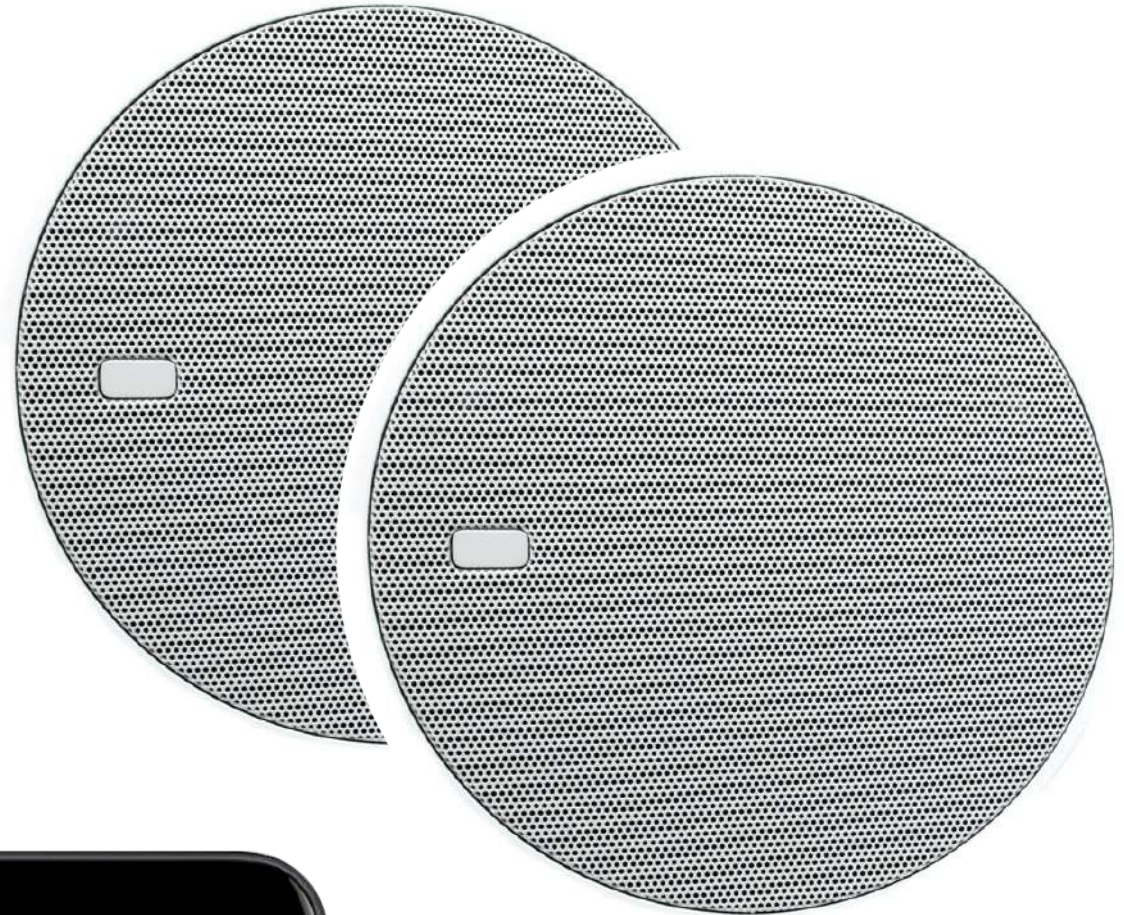

Perfect for home, a great solution for rooms of hotels, hospitals, schools or any public place ...

SoHo
collection

IN-WALL Bluetooth® AUDIO RECEIVER



In-Wall Bluetooth Audio receiver that can be paired with any device with Bluetooth® capabilities (A2DP / AVRCP).

Signal reach is 10/12 meters.

Designed to ensure security and avoid interferences from other users nearby, each Module has its own identification number.

Perfect for your home, ideal solution for hotel rooms, hospitals, schools and any public place... in the wall avoids theft.

The In-Wall Bluetooth kit, includes:

- In-Wall Bluetooth Audio Receiver
- Two 2 ½" 8Ω loudspeakers
- Power supply (15Vdc/0,8A)
- Adaptor FD1234AD-M for installation with FEDE decorative frames

WHITE



FD1234

GREY



FD1234-G

BLACK



FD1234-M

ADAPTOR



FD1234AD-M



Installation

Two 4Ω speakers can be connected, up to four 8Ω speakers and up to eight 16Ω speakers.

Maximum power 5 + 5W.

Features

Each module is identified as KINGBT-XXXX where XXXX is a serial number which permits the user to identify different Modules that can co-exist in the same installation.

The module is provided with a key for operating the Bluetooth® mode (ON/OFF).

External audio input: the module is also provided with a socket to connect a 3,5mm jack for an external audio input. When the user inserts the jack the audio output switches to the signal from the jack and has priority over the Bluetooth® signal.

GERMAN SOCKET

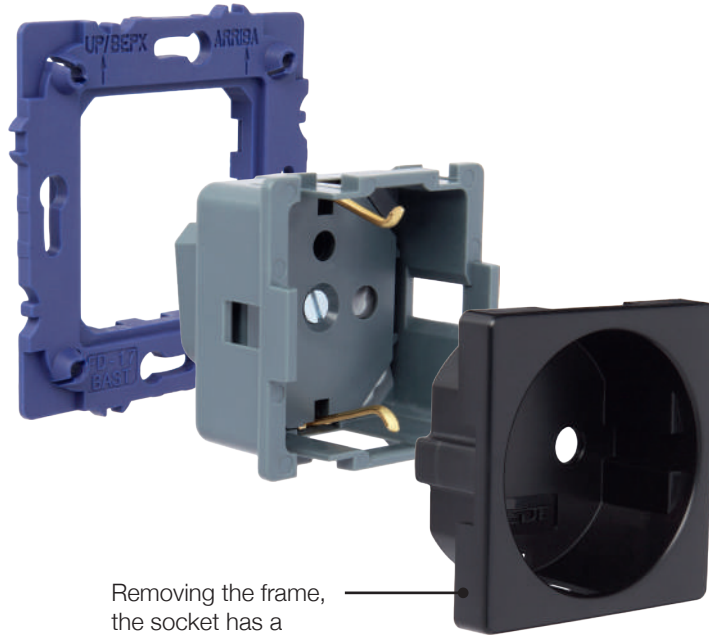

Removing the frame, the socket has a protection degree of IP21.



FD16-RING
Protection ring
Anneau de protection
Anello di protezione
Aro de protección
Isolierzubehör
Фланец из полиэтилена

FD16823
2P + E Socket outlets
Sortie de prises 2P + E
Base de enchufe 2P + E
2P + E Steckdosen
Розетка "2к + 3"
16 A 250 V



BRASS COVERS/COUVERTURE EN LAITON/COVERS IN OTTONE/TAPAS DE LATÓN/MESSINGABDECKUNGEN /ЛАТУННЫЕ НАКЛАДКИ ДЛЯ РОЗЕТОК

BRUSHED Nickel			
	FD04335BN	FD04335BN-A	FD04335BN-M
BRUSHED Graphite			
	FD04335BG	FD04335BG-A	FD04335BG-M
BRUSHED Brass			
	FD04335BB	FD04335BB-A	FD04335BB-M
BRUSHED Copper			
	FD04335BC	FD04335BC-A	FD04335BC-M

SOCKET FRONT PLASTIC COVERS
PRISE LARGE EN PLASTIQUE
COVER FRONTALE IN PLASTICA
BASES DE ENCHUFE DE PLÁSTICO
BREITE STECKDOSENABDECKUNGEN MIT DECKEL
ПЛАСТИКОВЫЕ НАКЛАДКИ ДЛЯ РОЗЕТОК

WHITE	BEIGE	BLACK

FD16723 FD16723-A FD16723-M
SOCKET FRONT COVERS WITH TAP
CLAPET LARGE POUR PRISE
COVERS FRONTALE PER PRESA
TAPAS FRONTALES PARA BASES DE ENCHUFE
STECKDOSENABDECKUNG MIT DECKEL
НАКЛАДКИ ДЛЯ РОЗЕТОК С КРЫШКОЙ IP44

WHITE	BEIGE	BLACK
FD16911	FD16911-A	FD16911-M

SoHo
collection



FD16623
 2P + E Socket outlets
 Sortie de prises 2P + E
 Base de enchufe 2P + E
 2P + E Steckdosen
 Розетка "2к + 3"
 10-16 A 250 V

BRASS COVERS/COUVERTURE EN LAITON/COVERS IN
 OTTONE TAPAS DE LATÓN/MESSINGABDECKUNGEN
 /ЛАТУННЫЕ НАКЛАДКИ ДЛЯ РОЗЕТОК



FD04324BN FD04324BN-A FD04324BN-M

BRUSHED Nickel



FD04324BG FD04324BG-A FD04324BG-M

BRUSHED Graphite



FD04324BB FD04324BB-A FD04324BB-M

BRUSHED Brass



FD04324BC FD04324BC-A FD04324BC-M

BRUSHED Copper

SOCKET FRONT PLASTIC COVERS
 PRISE LARGE EN PLASTIQUE
 COVER FRONTALE IN PLASTICA
 BASES DE ENCHUFE DE PLÁSTICO
 BREITE STECKDOSENABDECKUNGEN MIT DECKEL
 ПЛАСТИКОВЫЕ НАКЛАДКИ ДЛЯ РОЗЕТОК



FD16071 FD16071-A FD16071-M
 SOCKET FRONT COVERS WITH TAP
 CLAPET LARGE POUR PRISE
 COVERS FRONTALE PER PRESA
 TAPAS FRONTALES PARA BASES DE ENCHUFE
 STECKDOSENABDECKUNG MIT DECKEL
 НАКЛАДКИ ДЛЯ РОЗЕТОК С КРЫШКОЙ IP44



FD16902 FD16902-A FD16902-M

SoHo
 collection

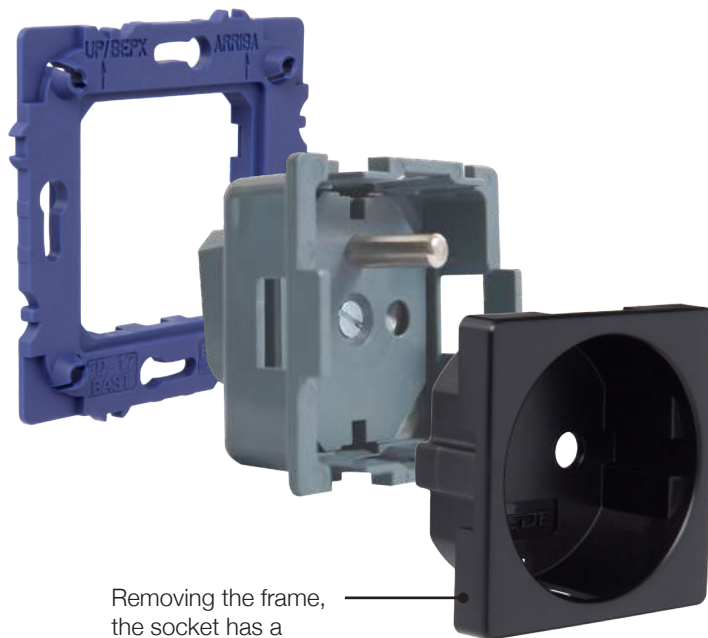

Removing the frame,
 the socket has a
 protection degree
 of IP21.



FD16-RING
 Protection ring
 Anneau de protection
 Anello di protezione
 Aro de protección
 Isolierzubehör
 Фланец из полиэтилена



FRENCH SOCKET



BRITISH SOCKET



BRASS COVERS/COUVERTURE EN LAITON/
COVERS IN OTTONE/TAPAS DE LATÓN
MESSINGABDECKUNGEN
ЛАТУННЫЕ НАКЛАДКИ ДЛЯ РОЗЕТОК

BRUSHED Nickel	BRUSHED Graphite	BRUSHED Brass	BRUSHED Copper
 FD20000BN	 FD20000BG	 FD20000BB	 FD20000BC
 FD20000BN-A	 FD20000BG-A	 FD20000BB-A	 FD20000BC-A
 FD20000BN-M	 FD20000BG-M	 FD20000BB-M	 FD20000BC-M













16A 230V

WHITE	BEIGE	BLACK
 FD20000B	 FD20000AB	 FD20000MB

AMERICAN SOCKET



BRASS COVERS/COUVERTURE EN LAITON/
COVERS IN OTTONE/TAPAS DE LATÓN
MESSINGABDECKUNGEN
ЛАТУННЫЕ НАКЛАДКИ ДЛЯ РОЗЕТОК

BRUSHED Nickel	BRUSHED Graphite	BRUSHED Brass	BRUSHED Copper
 FD22000BN	 FD22000BG	 FD22000BB	 FD22000BC
 FD22000BN-A	 FD22000BG-A	 FD22000BB-A	 FD22000BC-A
 FD22000BN-M	 FD22000BG-M	 FD22000BB-M	 FD22000BC-M

15A 127V

WHITE	BEIGE	BLACK
 FD22000	 FD22000-A	 FD22000-M

SoHo
collection

BRASS COVERS/COUVERTURE EN LAITON/
COVERS IN OTTONE/TAPAS DE LATÓN/
MESSINGABDECKUNGEN/
ЛАТУННЫЕ НАКЛАДКИ ДЛЯ РОЗЕТОК

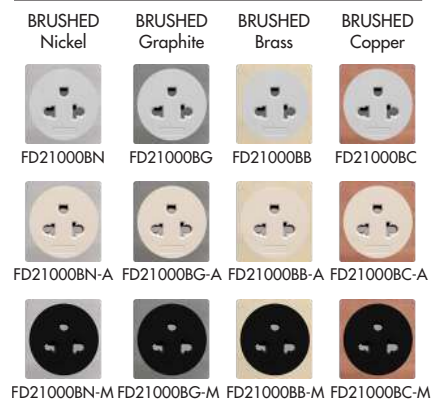

16 A 230 V



2P Universal socket outlet
(16 A 2 pins Ø 4,8 European plug)
(15 A American plug)
Pack of 20 units

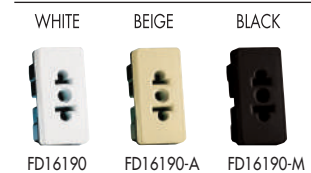

2P + E Universal socket outlet
(16 A 2 pins Ø 4,8 European plug)
(15 A American plug)
Pack of 20 units

EURO-AMERICAN SOCKET



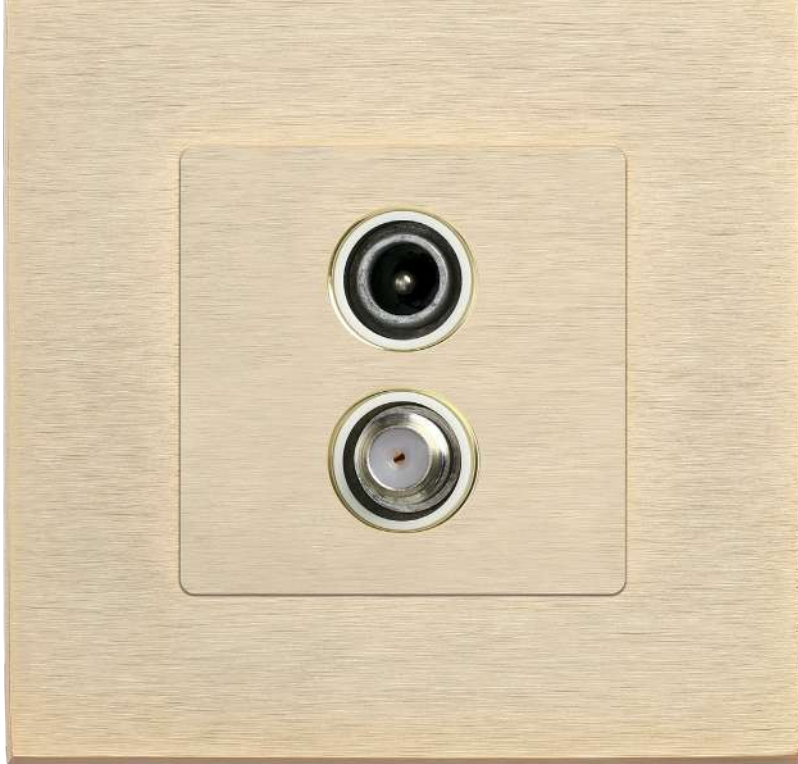

TV/SAT Socket Outlets

We are offering wide range of professional TV/SAT socket outlets:

The compact dimension of the mechanisms ensure fixation of cables and installation to the mounting box in the wall.

BRASS TV/SAT COVERS / COUVERTURES TV/SAT EN LAITON / TAPAS TV/SAT DE LATÓN / МОНТАЖНЫЕ ПЛАТЫ ДЛЯ РОЗЕТОК TV/SAT С ЛАТУННЫМИ НАКЛАДКАМИ



TV/SAT COVERS / COUVERTURES TV/SAT / TAPAS TV/SAT / ПЛАСТИКОВЫЕ МОНТАЖНЫЕ ПЛАТЫ ДЛЯ РОЗЕТОК TV/SAT

Cover for mechanism with single connector
Couverture pour la prise avec un connecteur simple
Tapa para toma con 1 conector
Монтажная плата для механизмов с одним коннектором

Cover for mechanism with double connector
Couverture pour la prise avec un connecteur double
Tapa para toma con doble conector
Монтажная плата для механизмов с двумя коннекторами



WIDE/LARGE/ANCHAS/ШИРОКИЕ МОДУЛИ

NARROW/CLAIR/ESTRECHAS/УЗКИЕ МОДУЛИ

½ TV Please see on page 53 to combine this item with multimedia.

NEW UNIVERSAL COVER!

SoHo
collection

TV/SAT SOCKET OUTLETS

- DIECAST BOXES
- SMALL DIMENSIONS
- HIGH EFFICIENCY SHIELD > 90 dB
- ULTRA WIDE BAND WITHIN 4/ 2350 MHZ
- HIGH LINEARITY AND RETURN LOSS IN WHOLE BAND
- SILVERED CONTACTS
- SUITABLE FOR DIGITAL AND ANALOG TV/SAT SIGNALS



Door opening angle greater than 180° in order to facilitate the installation even under difficult conditions.



Features:

- Facilitated entrance of the door screw.
- Curvature designed to tightening different diameters cables in uniform way.

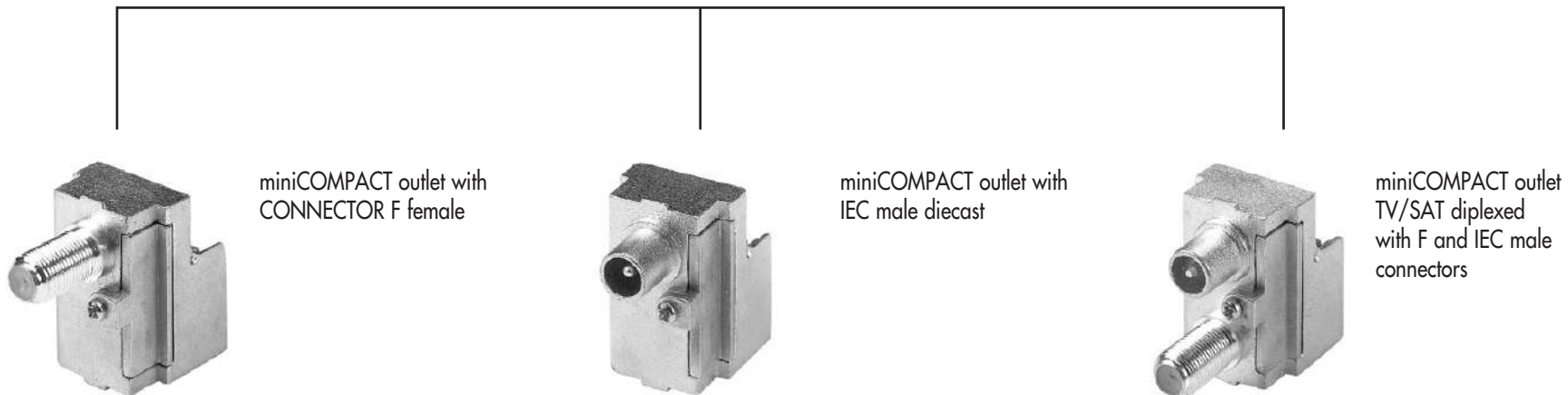
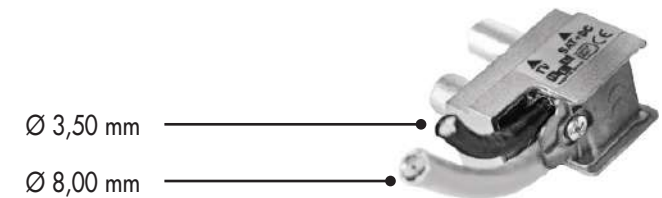

miniCOMPACT outlet with CONNECTOR F female

miniCOMPACT outlet with IEC male diecast

miniCOMPACT outlet TV/SAT diplexed with F and IEC male connectors

SoHo
collection

miniCOMPACT OUTLET SERIES / PRISES TV/SAT SERIE miniCOMPACT / TOMAS TV/SAT SERIE miniCOMPACT

Single sockets TV or SAT

CODE	SCHEME	DESCRIPTION	MODEL	TYPICAL USE
FD001F/DC		Terminal IEC pin RF with DC		TV system DC with a single connectivity RETRO TV
FD002F		Terminal F-OUT RF socket with DC		SAT network with multiswitch 4/8
FD001F		End IEC pin OUT RF isolated		Terminal TV socket for network with a "cascade" connection
FD506F		Passageway IEC pin OUT RF isolated	3 dB 6 dB 10 dB 14 dB 18 dB 22 dB	TV network DC with a "cascade" connection

Sockets TV/SAT

CODE	SCHEME	DESCRIPTION	MODEL	TYPICAL USE
FD010F		End OUT SAT with DC OUT TV isolated		TV / SAT networks with a "star" connection
FD011F		End Independent inputs OUT SAT with DC OUT TV isolated		With independent connections of two cables
FD013F		End OUT SAT isolated OUT TV isolated		End TV / SAT socket for network with a "cascade" connection.
FD220F		Passageway OUT SAT isolated OUT TV isolated	3 dB 6 dB 10 dB 14 dB	TV / SAT networks with a "cascade" connection

Notes: DC-diode set between OUT and IN. For more information on connection diagrams, see page 71.

COMPACT OUTLET SERIES / PRISES SERIE COMPACT / TOMAS SERIE COMPACT



FD090F

Aluminum alloy support
for fixing connectors



FD091F

F-F connector



FD092F

F-IEC-pin connector

The FD090F support is made of an aluminum alloy with a high shielding ability and, depending on your needs, allows mounting one or two FD091F or FD092F connectors. This kit is installed in the circuit boards. Despite the fact that ecoCOMPACT is the most economical solution, it has a very wide operating range from 4 to 235 MHz and provides compatibility with analog and digital TV / SAT signals.

MULTIMEDIA SOCKETS



FEDE+ presents a new product line of brass covers for Multimedia sockets. Our new decorative covers provide a luxury finish to Multimedia outlets thanks to their excellent quality.

COVERS FOR MULTIMEDIA SOCKETS / COUVERTURE EN LAITON POUR LES PRISES MULTIMÈDIA /
TAPAS CONNETTORI MULTIMEDIALI PER BRASS / TAPAS PARA CONECTORES MULTIMEDIA DE LATÓN /
TAPAS CONNECTORS MULTIMEDIA FÜR BRASS / ЛАТУННЫЕ НАКЛАДКИ ДЛЯ МУЛЬТИМЕДИЙНЫХ РОЗЕТОК

BRUSHED
Nickel



FDO4317BN-A (Beige)
FDO4317BN-M (Black)

BRUSHED
Graphite



FDO4317BG-A (Beige)
FDO4317BG-M (Black)

BRUSHED
Brass



FDO4317BB-A (Beige)
FDO4317BB-M (Black)

BRUSHED
Copper



FDO4317BC-A (Beige)
FDO4317BC-M (Black)



FDO4318BN-A (Beige)
FDO4318BN-M (Black)



FDO4318BG-A (Beige)
FDO4318BG-M (Black)

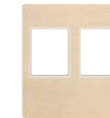

FDO4318BB-A (Beige)
FDO4318BB-M (Black)



FDO4318BC-A (Beige)
FDO4318BC-M (Black)

COVERS FOR MULTIMEDIA SOCKETS / COUVERTURE EN PLASTIQUE POUR LES PRISES MULTIMÈDIA /
TAPAS CONNETTORI MULTIMEDIALI PER PLASTICA / TAPAS PARA CONECTORES MULTIMEDIA DE PLÁSTICO /
TAPAS CONNECTORS MULTIMEDIA FÜR KUNSTSTOFF/ ПЛАСТИКОВЫЕ НАКЛАДКИ ДЛЯ МУЛЬТИМЕДИЙНЫХ РОЗЕТОК

Single mounting plate
Pack of 10 units

WHITE

BEIGE

BLACK

Plaque pour le montage d'une prise multimédia
Pack de 10 unités



Módulo para el montaje de 1 conector multimedia
Pack de 10 unidades

FD17896

FD17896-A

FD17896-M

Double mounting plate
Pack of 10 units

Plaque pour le montage deux prise multimédia
Pack de 10 unités



FD17897

FD17897-A

FD17897-M

Módulo para el montaje de 2 conectores multimedia
Pack de 10 unidades

NARROW/CLAIR/ESTRECHAS

½ TV Please see on
page 50 to combine
this item with TV/SAT.

WHITE

BLACK









NEW!







FD17898

FD17898-M

PHONE, COMPUTER AND AUDIO CONNECTORS / GAMME MULTIMÉDIA / GAMA MULTIMEDIA

	6 contacts phone socket For RJ-11 connector Cat. 3e Pack of 1 unit.	Prise téléphonique de 6 voies Pour le connecteur RJ-11. Cat. 3e Pack de 10 unités.	Toma teléfono 6 vías Para conector RJ-11. Cat. 3e Pack de 1 unidad.	FD-T3-B	FD-T3-M
	Information outlets (internet), Cat. 6e Pack of 1 unit.	Prise informatique (Internet), Cat.6e Pack de 1 unité.	Toma informática (Internet), Cat. 6e Pack de 1 unidad.	FD-T6-B	FD-T6-M
	HDMI connector Pack of 1 unit	Connecteur HDMI Pack de 1 unité.	Conector HDMI Pack de 1 unidad	FD-210HD	FD-210HD-M
	USB connector Jack-to-jack connection, 2.0A-A, nickel coating Pack of 1 unit	Connecteur USB Connexion Jack -to-jack, 2.0A-A, finition en nickel Pack de 1 unité.	Conexión USB Conector Jack-to-jack, 2.0A-A, acabado en níquel Pack de 1 unidad	FD-210USB	FD-210USB-M
	RCA connector, Audio, nickel coating Pack of 1 unit	Connecteurs RCA Audio, finition nickel Pack de 1 unité.	Conector RCA Audio, acabado en níquel Pack de 1 unidad	FD-310RSA-YL	FD-310RSA-YL-M
	BANANA audio outlet Pack of 1 unit	BANANA connecteur audio Pack de 1 unité.	BANANA conector audio Pack de 1 unidad	Red / Rouge / Rojo Black / Noir / Negro FD-BJ-B-R FD-BJ-B-M	FD-BJ-M-R FD-BJ-M-M
	Audio outlet for plugs Ø3.5mm Pack of 1 unit	Prises Jack audio Ø3.5mm Pack de 1 unité.	Toma de audio para enchufes Ø3.5 mm Pack de 1 unidad	FD-35S-B	FD-35S-M
	Self-clamping audio outlet Pack of 1 unit	Prise audio à pinces Pack de 1 unité.	Toma de audio de pinzas Pack de 1 unidad	FD-310ST	FD-310ST-M
NEW! 	Shielded Silver Toolless Cat. 6a 10G, 500Mhz. Pack of 1 unit	Cat. 6a sans argent blindé 10G, 500Mhz. Pack de 1 unité.	Toma teléfono Cat. 6a con tapa de protección en plata. 10G, 500Mhz. Pack de 1 unidad		FD-T6A

FIBER-OPTIC CONNECTORS / CONNECTEURS OPTIQUES FIBRES / CONECTORES DE FIBRA ÓPTICA

	ST connector PB sleeve, 19.20mm Individual Pack of 1 unit	Douille de connecteur PB ST, 19,20 mm Pack individuel de 1 unité	Manga de conector PB ST, 19.20mm Pack Individual de 1 unidad	FD-1D2/ST (White) FD-1D2/ST (БЕЛЫЙ) FD-1D2/ST (BLANCO)
	LC flangeless connector PB sleeve, 19.20mm Individual Pack of 1 unit	Support Sleeve PB Connecteur LC, 19,20 mm Pack individuel de 1 unité	Manga de apoyo conector PB LC, 19.20mm Pack Individual de 1 unidad	FD-2D2/LC (White) FD-2D2/LC (БЕЛЫЙ) FD-2D2/LC (BLANCO)
	SC flangeless connector PB sleeve, 19.20mm Individual package: 1pc.	Support Sleeve PB Connecteur LC, 19,20 mm Pack individuel de 1 unité	Manga de apoyo conector PB SC, 19.20mm Pack Individual de 1 unidad	FD-2D2/SC (White) FD-2D2/SC (БЕЛЫЙ) FD-2D2/SC (BLANCO)
	Security boot for duplex LC connector Individual package: 1pc.	Accessoire de verrouillage pour connecteur LC duplex Pack individuel de 1 unité	Accesorio de bloqueo para conector LC dúplex Pack Individual de 1 unidad	FD-OSRLL
	Removal key for FD-OSRLL Individual package: 1pc.	Outil pour extraire FD-OSRLL Pack individuel de 1 unité	Herramienta para extraer FD-OSRLL Pack Individual de 1 unidad	FD-33013

ACCESSORIES FOR MULTIMEDIA SOCKETS / ACCESSOIRES POUR CONNECTEURS MULTIMÉDIA / ACCESORIOS PARA CONECTORES MULTIMEDIA

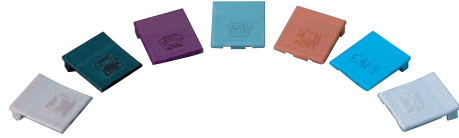

Shutters with
designation symbols
Package: 50 pcs

Casquettes avec des symboles
signalisation
Pack de 50 unités

Tapas con símbolos
de señalización
Pack de 50 unidades

FD-ICON-D-XX
FD-ICON-V-XX
FD-ICON-C-XX
FD-ICON-5e-XX
FD-ICON-N-XX
FD-ICON-6-XX

D – DATA (monitor/moniteur / monitor)
V – VOICE (telephone/téléphone / teléfono)
C – Cat. 5
5e – Cat. 5e
N – without marking
6e – Cat. 6

When ordering shutters it is necessary to add the appropriate color codes: beige (IV), white (WH), grey (GY), black (BK), red (RD), orange (OR), blue (BL), green (GN), yellow (YL)
Pour commander les couvertures, il est nécessaire d'indiquer les codes de couleurs appropriés: beige (IV), blanc (WH), gris (GY), noir (BK), rouge (RD), orange (O), bleu (BL), vert (GN), jaune (YL).
Para solicitar las tapas es necesario indicar los códigos de color apropiado: beige (IV), blanco (WH), gris (GY), negro (BK), rojo (RD), naranja (O), azul (BL), verde (GN), amarillo (YL).

	Plug Designed for closing the unused seat on the mounting plate Pack of 10 units	Connecteur Conçu pour la fermeture du module de montage sans utiliser Pack de 10 unités	Conector Diseñado para el cierre del módulo de montaje sin usar Pack de 10 unidades	FD-ISKWH
---	--	---	---	----------

OUTLETS FOR 6E CATEGORY INFORMATION NETWORKS / CATÉGORIES INFORMATIQUES 6 / TOMAS INFORMÁTICAS CATEGORÍA 6

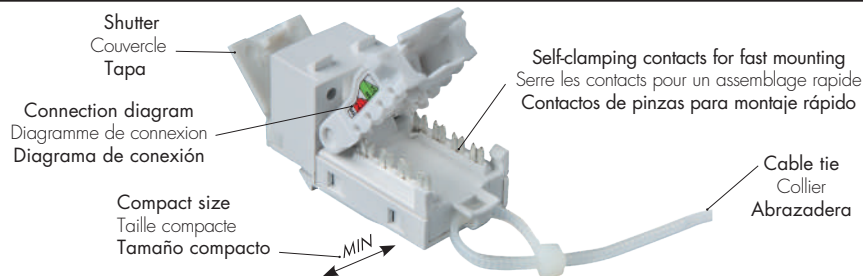

Bronze gold-plated contacts
Contacts recouverts d'or et de bronze
Contactos recubiertos de oro y bronce

Shutter holders
Clip de couverture
Sujetador de tapas

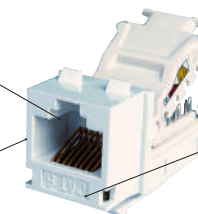

Category designation
Désignation de catégorie
Designación de categoría

DEVICES TO INCREASE COMFORT

THERMOSTAT WITH METAL COVER

FEDE+ presents a wide range of electronic devices to provide you with a more comfortable lifestyle. Thermostats for air temperature control, under floor heating and new multi-function thermostat.

For those who prefer original finishes made in brass in perfect combination with our covers, **FEDE** has developed a new version of our technologically advanced electronic thermostats.



FAN COIL THERMOSTAT



*ITEMS' REAL SIZE ARE SHOWN IN THE IMAGES

THERMOSTATS / TERMOSTATI / THERMOSTATOS / THERMOSTATE / ТЕРМОСТАТЫ



Thermostat for electrical heating floors control
16 A 230V ± 10%, 50-60 Hz,
Temperature control range: 5-45°C

Cable 4m. with sensor for electrical heating floors included in package.
Pack of 1 unit

Termostato para suelos radiantes
16 A 230 V ± 10%, 50-60 Hz,
Rango de control de temperatura: 5-45°C
Cable de 4m. con sensor de suelo radiante eléctrico incluido en el paquete.
Pack de 1 unidad

Термостат для управления теплыми полами
16 А 230 В ± 10%, 50-60 Гц,
Регулируемый диапазон температуры: 5-45°C
Кабель с датчиком температуры пола длиной 4 метра в комплекте
Упаковка: 1 шт.



Thermostat for room temperature control
16 A 230V ± 10%, 50-60 Hz,
Temperature control range: 5-45°C
Pack of 1 unit

Para control de temperatura de habitación 16 A 230 V ± 10%, 50-60 Hz,
Rango de control de temperatura: 5-45°C. Pack de 1 unidad

Термостат для управления комнатной температурой
16А 230 В ± 10%, 50-60Гц,
Регулируемый диапазон температуры: 5-45°C
Упаковка: 1 шт.



Multi-function Thermostat
Pack of 1 unit

Termostato Multifunción
Pack de 1 unidad

многофункциональный термостат
Кабель с датчиком температуры пола длиной 4 метра в комплекте
Может работать в следующих режимах:
Контроль температуры воздуха, контроль температуры теплого пола и комбинированном
Упаковка: 1 шт

FAN COIL THERMOSTAT / NUEVO VENTILOCONVECTOR (FAN COIL) / ТЕРМОСТАТЫ



Fan Coil Thermostat
Pack of 1 unit

Ventiloconvector (Fan Coil)
Pack de 1 unidad

Термостат для фанкойлов
Упаковка: 1 шт

COLORS OF BRASS FRONT COVERS / COLORS OF PLASTIC SUPPORTS AND BUTTONS
ЦВЕТА ЛАТУННЫХ ФРОНТАЛЬНЫХ НАКЛАДОК / ЦВЕТА ПЛАСТИКОВЫХ КЛАВИШ

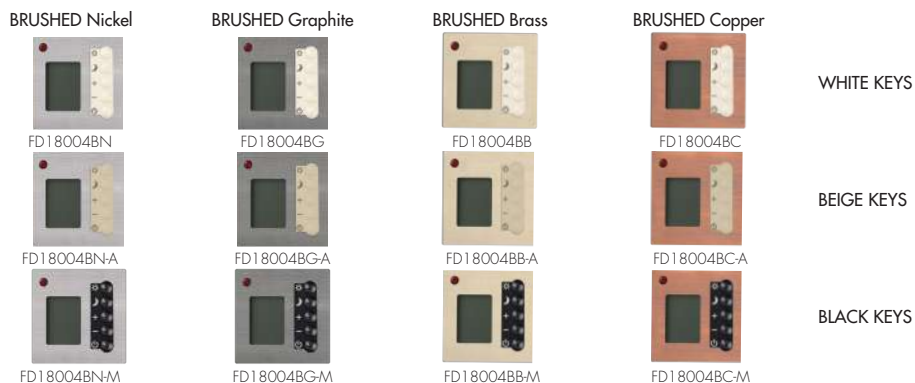
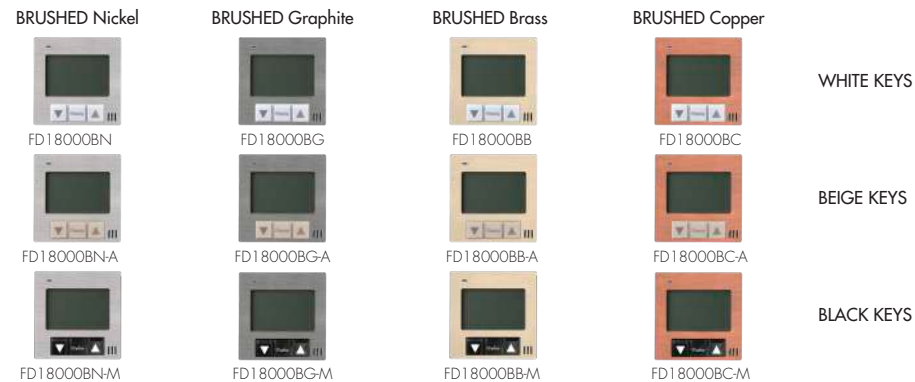

NEW CORD OUTLETS



NEW CORD OUTLETS / SORTIE DE CÂBLE / SALIDA DE CABLE / МЕХАНИЗМ ВЫВОД ДЛЯ КАБЕЛЯ

With fixing clamp up to
Ø8mm.

Con brida de sujeción de hasta
Ø 8 mm.

В комплекте поставляется кабельная
стяжка для фиксации проводов

WHITE

BEIGE

BLACK



FD18034



FD18034-A



FD18034-M

Pack of 10 units / Pack de 10 unités / Pack de 10 unidades / Упаковка: 10 шт.

NEW BRASS BLANK PLATES



NEW BRASS BLANK PLATES / NUEVAS TAPAS CIEGAS DE LATÓN / ЛАТУННЫЕ ЗАГЛУШКИ

BRUSHED Nickel BRUSHED Graphite BRUSHED Brass BRUSHED Copper



FD04319BN



FD04319BG



FD04319BB



FD04319BC

NEW PLASTIC BLANK PLATES / NUEVAS TAPAS CIEGAS DE PLÁSTICO / ПЛАСТИКОВЫЕ ЗАГЛУШКИ

WHITE BEIGE BLACK



FD17033



FD17033-A



FD17033-M

Pack of 10 units / Pack de 10 unités / Pack de 10 unidades / Упаковка: 10 шт.

SoHo
collection

SUPPORT FOR FIXING ALL MECHANISMS / SUPPORT DE FIXATION POUR TOUS LES MÉCANISMES / SUPPORTI DI FISSAGGIO PER TUTTI I MECCANISMI SOPORTE DE FIJACIÓN PARA MECANISMOS/BEFESTIGUNGSHALTER FÜR ALLE MECHANISMEN / ПОДДЕРЖКА ФИКСАЦИИ ВСЕХ МЕХАНИЗМОВ

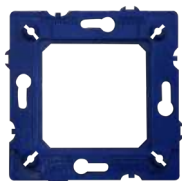

FD17-BAST

Polyamide support for fixing mechanisms.
Pack of 1 unit.

Support de fixation en polyamide pour les mécanismes.
Pack de 1 unité.

Bastidor de poliamida reforzado con fibra de vidrio para la fijación de mecanismos.
Pack de 1 unidad.

Polyamid-Halter für Mechanismusbefestigung
Enheilige Verpackung

Суппорт из полиамида
для установки механизмов. Упаковка 20 шт.

New!

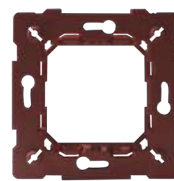

FD18-BAST

COMPATIBLE WITH ALL BRITISH SYSTEM ELECTRICAL MECHANISMS FROM OUR BRITISH RANGE.

COMPATIBLE CON TODOS LOS MECANISMOS ELÉCTRICOS DEL SISTEMA BRITÁNICO.

Polyamide support for fixing mechanisms. This fixing support is prepared for installation into the European standard installation boxes, only for mechanisms from BS or Italian catalogues.

SopORTE de fijación de poliamida para mecanismos de la gama británica. Este soporte de fijación está preparado para su instalación en las cajas de instalación estándar europeas.

For more information, please contact our Sales Department.

Para más información, póngase en contacto con nuestro Departamento de Ventas.

INSTALLATION ACCESSORIES

SQUARE INSTALLATION BOX FOR CONCRETE/BRICK WALLS. Joinable | CAISSE STANDARD CARRÉE. Joignable. | CASSA QUADRATA STANDARD. Montabile | CAJA CUADRADA ESTÁNDAR. Acoplable. | VIERECKIGE STANDARDBOX. Für Hohlwände.



FD2373

71 x 71 x 43 mm

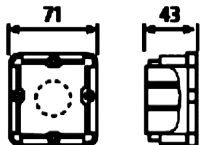

FD2374-1

Tapa protección
Permite localizar las
cajas después de enlucir



FD2375

Protection cover for support.
Защитная крышка для суппорта
Tapa de protección para bastidor.

Protection cover, can be used to protect the installation support against the paint and construction dust, during construction works. It allows you to control the connected switches mechanisms. Suitable for multiple use.

Защитная крышка, используется для защиты суппорта от попадания краски и строительной пыли, во время отделочных работ.

Позволяет управлять подключенными механизмами выключателей.

Пригодна для многократного использования.

Tapa de protection, se utiliza para proteger el bastidor y los mecanismos contra la pintura y polvo de construcción, durante la obra.



FD316

75 x 75 x 42 mm

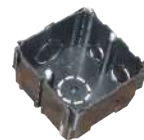
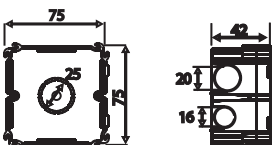

FD318

75 x 75 x 60 mm

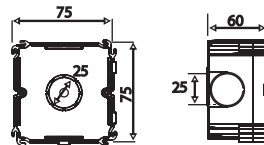

UNIVERSAL COVER (SPECIALLY FOR BOXES: FD404, FD406, FD407)
COUVERTURE UNIVERSELLE (ESPECIAL POUR: FD404, FD406, FD407)
COVERS UNIVERSALE (SPECIALMENTE PER: FD404, FD406, FD407)
TAPA UNIVERSAL (EN ESPECIAL PARA: FD404, FD406, FD407)
UNIVERSELLE ABDECKUNG (SPEZIELL FÜR DIE PACKUNGEN: FD404, FD406, FD407)



FD501001
Ø 60 mm

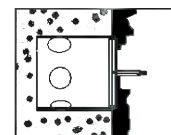
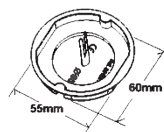

*To protect the boxes against the ingress of cement during the finishing works.
*Pour protéger les boîtes contre la pénétration de ciment durant les travaux de finition.
*Per proteggere le casse contro la penetrazione di cemento durante i lavori di finitura.
*Para proteger las cajas contra la entrada de cemento durante los trabajos de acabado.
*Um die Packungen vor dem Eindringen von Zement während der Ausbaurbeiten zu schützen.

FOR HOLLOW WALLS
 POUR LES MURS CREUX
 PER PARETI CONCAVE
 APTA PARA PLADUR
 FÜR HOHLWÄNDE
 КОРОБКИ ДЛЯ УСТАНОВКИ В СТЕНЫ ИЗ ГИПСОКАРТОНА

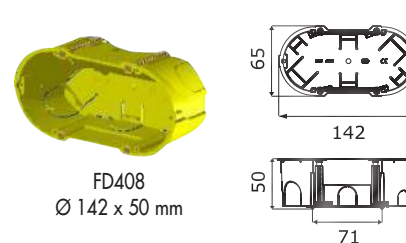
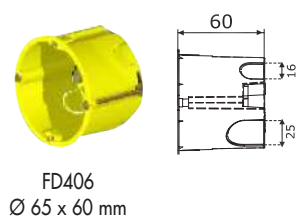
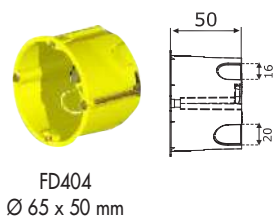
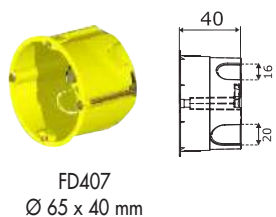

FD409
 Connector
 Accessoire de Jumelage
 Connettore
 Accesorio de Enlace
 Gruppenzubehör
 Соединительный коннектор для
 одиночных коробок

ROUND INSTALLATION BOX FOR CONCRETE/BRICK WALLS. Joinable.
 BOÎTE RONDE STANDARD POUR BÉTON/BRÍQUES. Joignable.
 CASSA ROTONDA STANDARD PER PARETI IN CALCESTRUZZO/MATTONI. Montabile.
 CAJA REDONDA ESTÁNDAR PARA PARED DE HORMIGÓN/LADRILLOS. Acoplable.
 RUNDE STANDARDBOX FÜR BETON-/ZIEGELWÄNDE. Anfügbar.
 КОРОБКИ ДЛЯ УСТАНОВКИ В СТЕНЫ ИЗ БЕТОНА

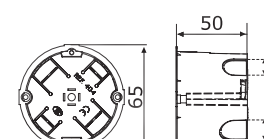
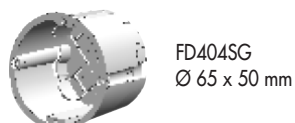
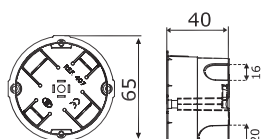
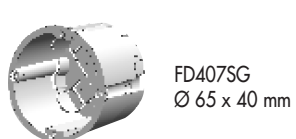



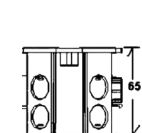
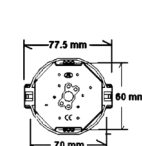
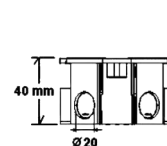
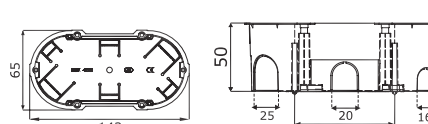
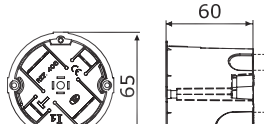



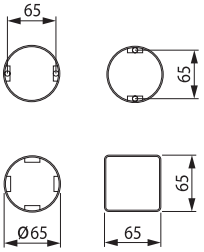

FD409SG
 Connector
 Accessoire de Jumelage
 Connettore
 Accesorio de Enlace
 Gruppenzubehör
 Соединительный коннектор для
 одиночных коробок

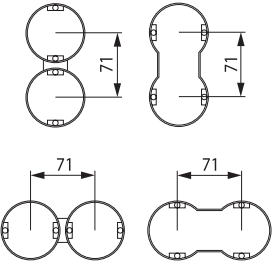
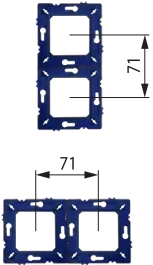

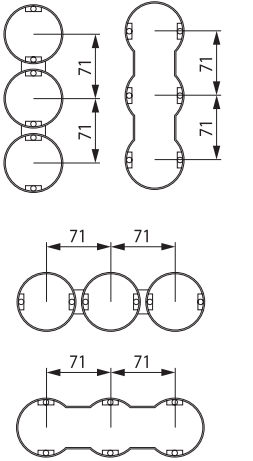
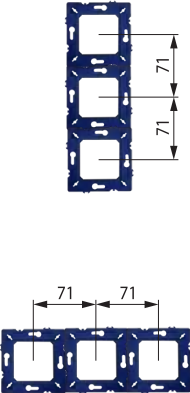
SoHo
 collection

INSTALLATION EXAMPLES

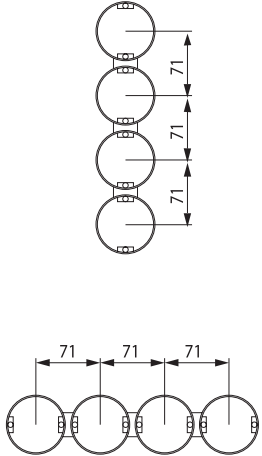
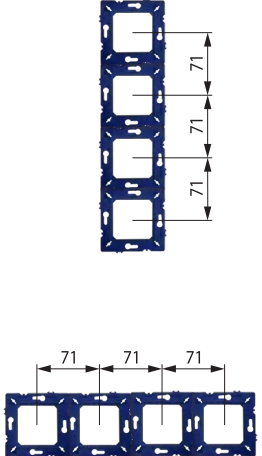
COMPOSITION	BOX	FIXING SUPPORT
 <p>1 MODULE</p>		
 <p>2 MODULES</p>		
 <p>3 MODULES</p>		

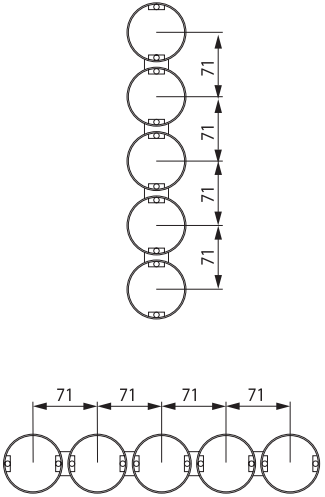
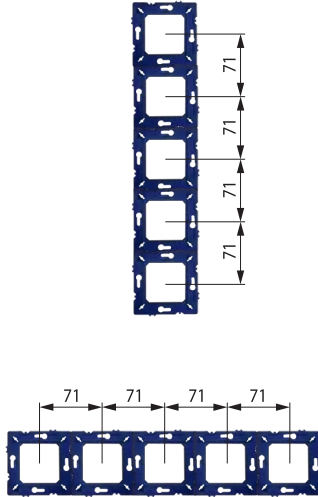
COMPOSITION	BOX	FIXING SUPPORT
 <p>4 MODULES</p>		
 <p>5 MODULES</p>		

COMPOSITION OF MOST USUAL ITEMS

DESCRIPTION	FRAME	MECHANISMS	TOGGLE /COVER/ HANDLE	LIGHT INDICATOR	BRASS COVER	FIXING SUPPORT
NEW 1 TOGGLE SWITCH	FD01701BB	FD16505	FD02318OB-M		FD04420P-A	FD17-BAST
NEW 2 TOGGLE SWITCHES	FD01701BB	FD16505 x 2	FD02317T-M x 2	FD21138-1 x 2	FD04421PD-A	FD17-BAST
1 WIDE KEY SWITCH	FD01701BB	FD16505	FD04310BB			FD17-BAST
NARROW KEY SWITCH	FD01701BB	FD16505 x2	FD04313BB x2	FD21139-2 x 2		FD17-BAST
ROTARY SWITCH	FD01701BB	FD03110-M	FD02309BB			FD17-BAST
ROTARY DIMMER	FD01701BB	FD16438-M	FD04336BB *OPTIONAL ITEM			FD17-BAST
BRASS ROTARY DIMMER	FD01701BB	FD016438BB	FD04336BB *OPTIONAL ITEM			FD17-BAST
TOUCH DIMMER	FD01701BB	FD28625-M				FD17-BAST

DESCRIPTION	FRAME	MECHANISMS	SOCKET COVER	FIXING SUPPORT
GERMAN SOCKET	FD01701BB	FD16823	FD04335BB	FD17-BAST
FRENCH SOCKET	FD01701BB	FD16623	FD04324BB	FD17-BAST
BRITISH SOCKET	FD01701BB		FD20000B	FD17-BAST
AMERICAN SOCKET	FD01701BB		FD22000BB	FD17-BAST
EURO AMERICAN SOCKET	FD01701BB		FD21000BB	FD17-BAST
USB CHARGER DOUBLE OUTPUT PORT	FD01701BB		FD-212USBBB-A	FD17-BAST

DESIGNATION OF COLORS IN CODES

FDXXXXX

Non-lettered codes are used for white items.

FDXXXXXAA

The letters at the end of the codes indicate the color of the item.

FDXXXXXAA-B

The letters after the dash indicate the color of the plastic base in articles with brass covers.

Color designations:

- A** — BEIGE
- M** — BLACK
- BN** — BRUSHED Nickel
- BG** — BRUSHED Graphite
- BB** — BRUSHED Brass
- BC** — BRUSHED Copper

Example:

FD04335BB-A — Socket cover

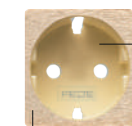

Plastic socket color = «A» — BEIGE

BRUSHED Brass cover color = «BB» — GOLD

CONNECTION DIAGRAMS OF SWITCHES AND PUSH BUTTONS

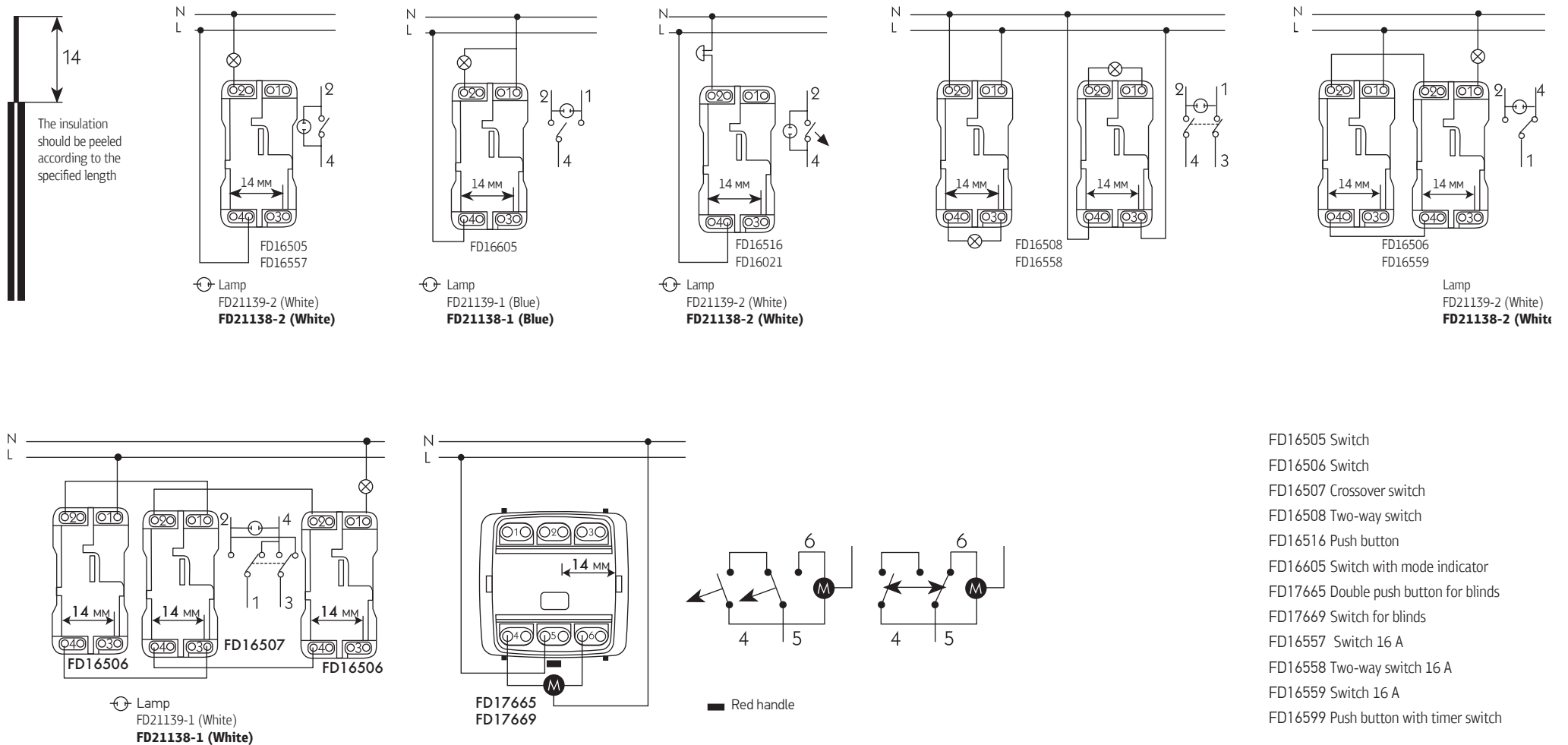

WARNING:

1. The codes of the diffuser lamps for the handle switches are indicated in **bold**.
2. When using the switches with diffuser for the control of low-energy lamps, the resistor FD3139 must be installed.

CONNECTION DIAGRAMS OF ROTARY SWITCHES

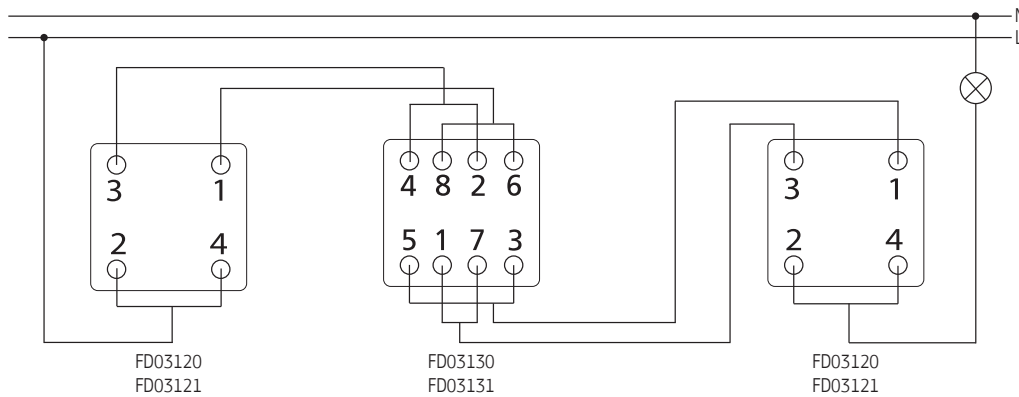
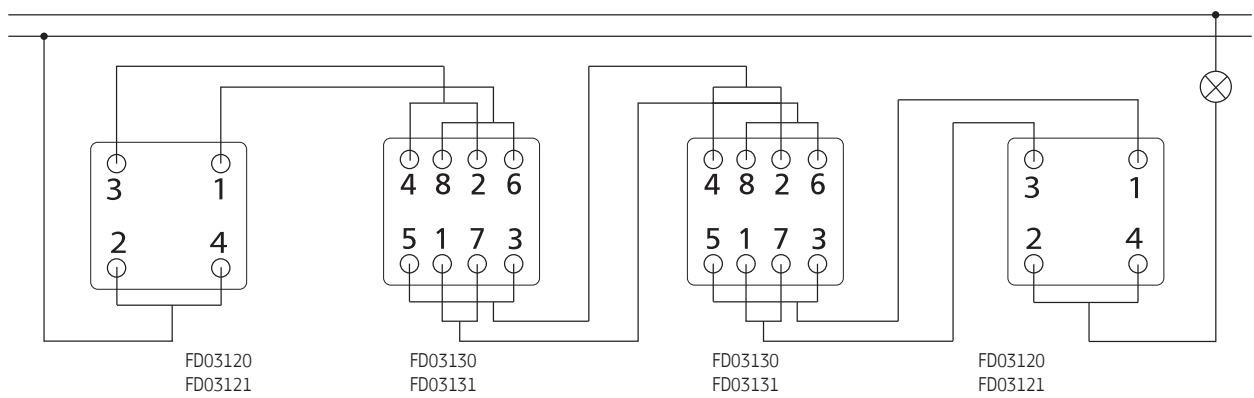
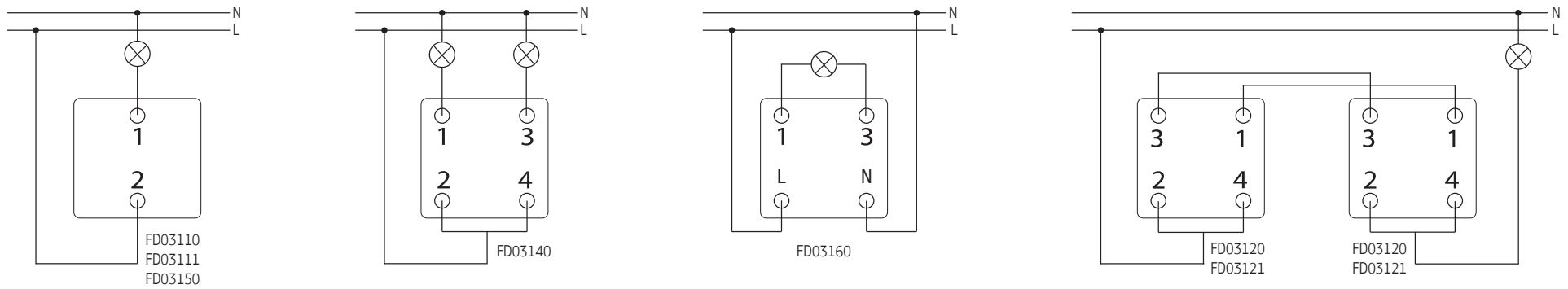

- FD03110 / FD03111** One-way rotary switch 10 A / One-way rotary switch 10 A for LED
- FD03120 / FD03121** Two-way rotary switch / Two-way rotary switch for LED
- FD03130 / FD03131** Intermediate rotary switch / Intermediate rotary switch for LED
- FD03140** Double one-way SP switch
- FD03150** One-way rotary switch 25 A
- FD03160** Double pole rotary switch 25 A

CONNECTION DIAGRAMS OF TOUCH SWITCHES

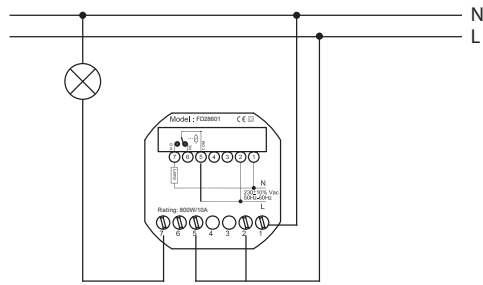

FD28601

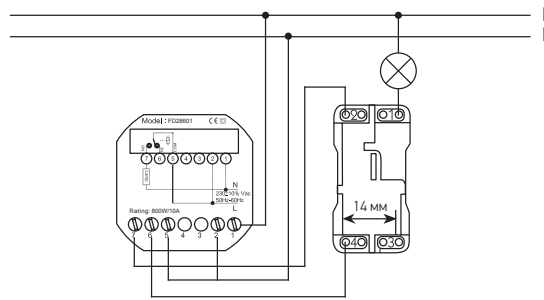

FD28601

FD16506

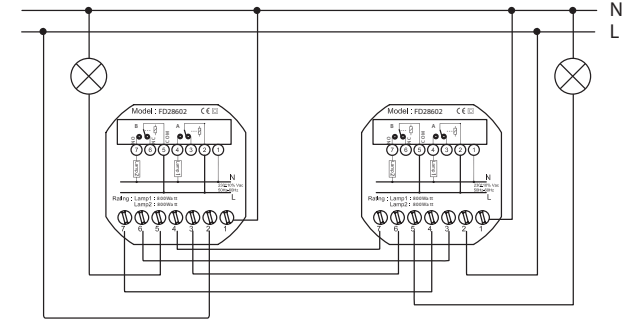

FD28602

FD28602

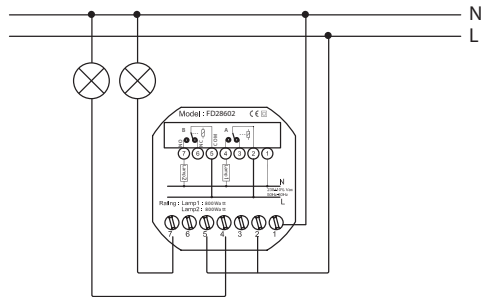

FD28602

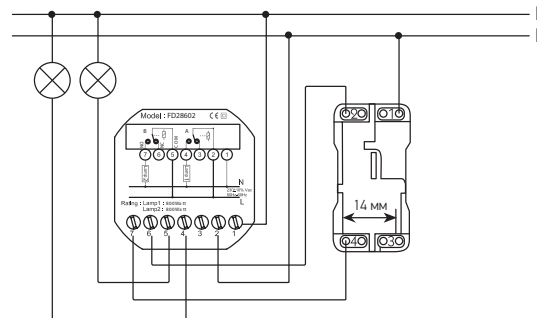

FD28602

FD16506

Using 1 channel

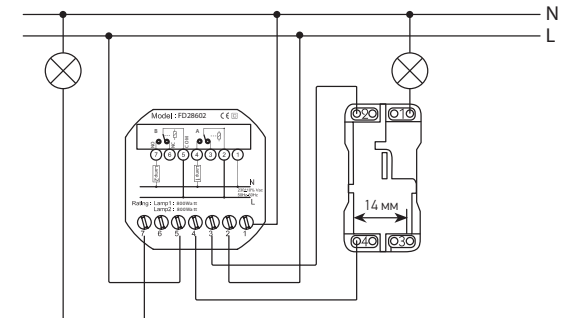

FD28602

FD16506

Using 2 channels

- FD28601** Individual-light switch
- FD28602** Double-key -light switch
- FD16506** Two-way SP switch

CONNECTION DIAGRAMS FOR ELECTRONIC DEVICES

Bathroom light switch FD28603

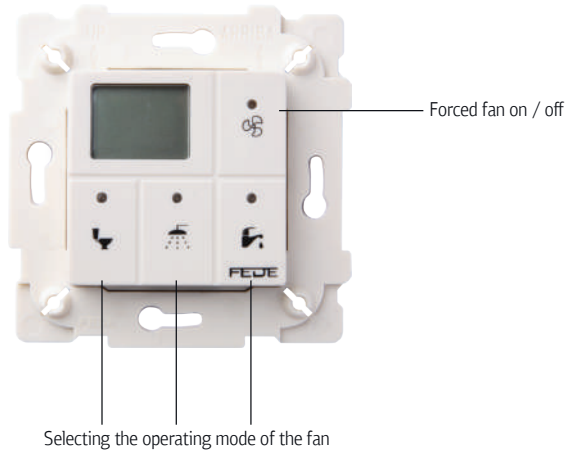

Includes both lighting and ventilation. When leaving the room, depending on the option of using the bathroom, the user presses the key with the corresponding symbol and the lighting goes out, while the ventilation continues to operate for a predetermined time. There is also the possibility to turn the fan on / off manually. The current setting and the operating mode are displayed on the LCD.

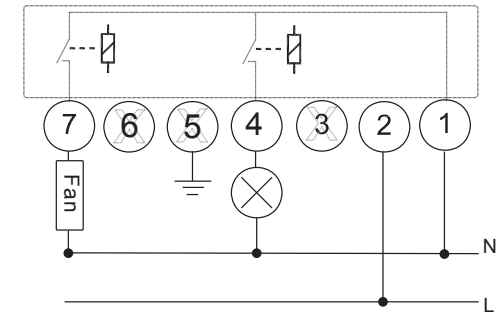

Infrared light switch FD28604

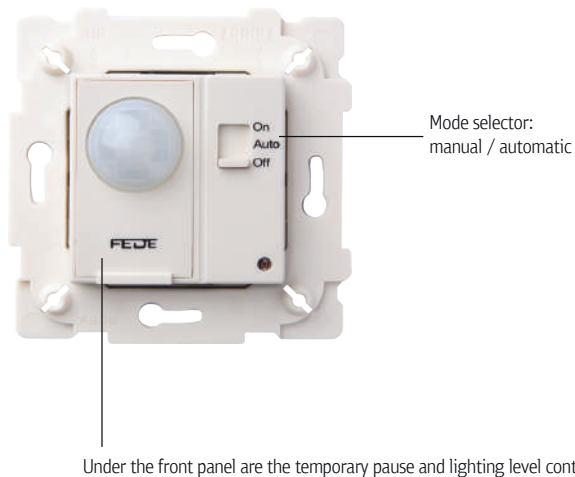

The presence detector switch allows devices to be activated automatically when a person is approaching (for example, lighting). To optimize the characteristics you can adjust the level of illumination, with which the device will be activated, as well as the duration of its operation. In addition, on the front of the device is a switch, which allows to force its activation or deactivation manually.

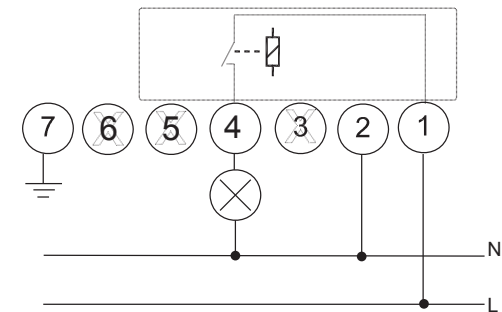

CONNECTION DIAGRAMS FOR DIMMERS

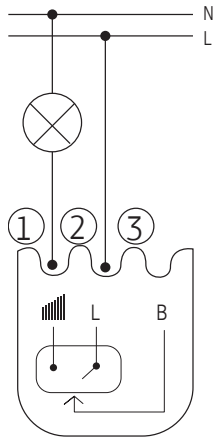

FD28625

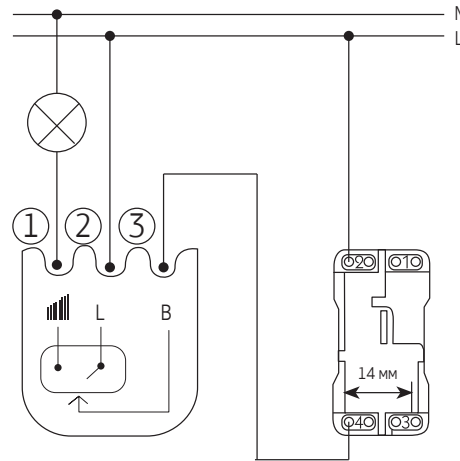

FD28625

FD16505

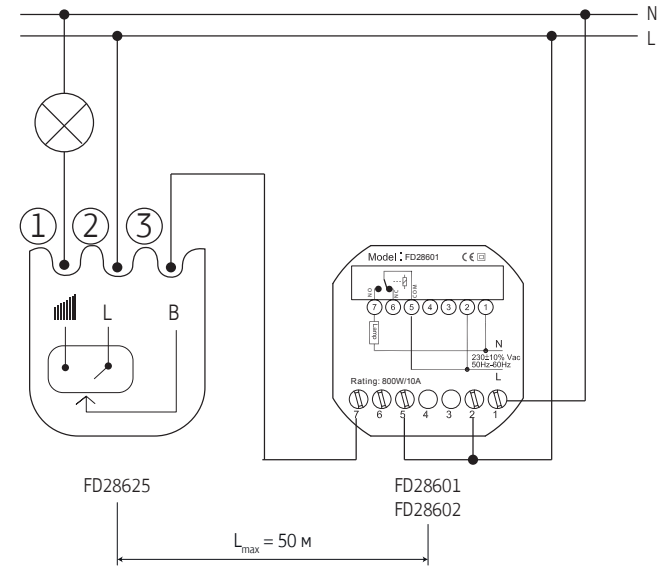

FD28625

FD28601
FD28602

$L_{max} = 50 \text{ m}$

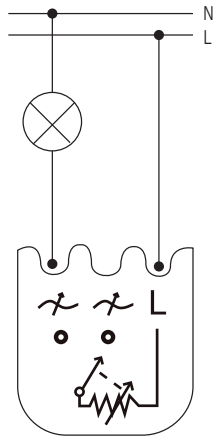

FD16438

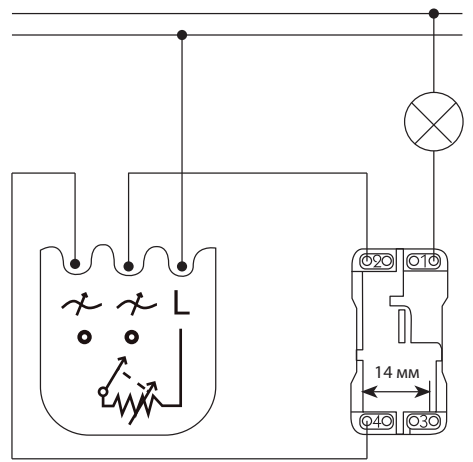

FD16438

FD16506

- FD16505** One-way SP switch
- FD16506** Two-way SP switch
- FD16438** Rotary dimmer
- FD28601** Individual-light switch
- FD28602** Double-key light switch
- FD28625** Compact touch dimmer for all FEDE frames collections

DIAGRAMS OF CONNECTION FOR DIMMERS FOR PUSH BUTTONS

To control the light regulators use the mechanisms of the push buttons FD16516 without LED.

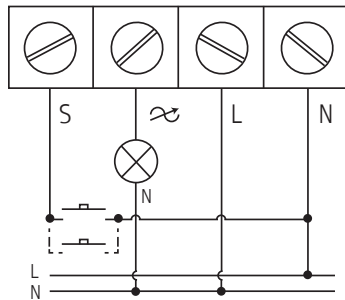

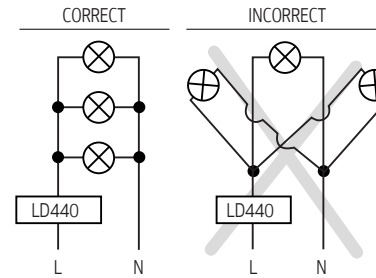

Load connection:

To reduce the level of electromagnetic interference, use a parallel connection of the load circuit.



- LD220** Dimmer for push button installation
- LD440** Dimmer for push button installation
- LD220WCM** Dimmer for push button installation
- LD220KRON** Dimmer for push button installation

TABLE FOR SELECTION OF DIMMERS

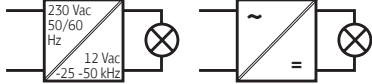
Code	Dimmer type			
		For incandescent and halogen lamps	For dimmable CFLs and LEDs with E14, E27 and GU10 base	For dimmable electronic transformers and LED drivers
FD16438	Rotary	750 W	No	No
FD28625	Touch	600 W	No	No
LD220	To install with push button	200 W	200 W	200 W
LD440	To install with push button	440 W	440 W	440 W
LD220WCM	To install with push button	200 W	200 W	200 W
LD220KRON	To install with push button	2×100 W	2×100 W	2×100 W

THERMOSTAT CONNECTION DIAGRAMS

Thermostats FD18000/FD18001

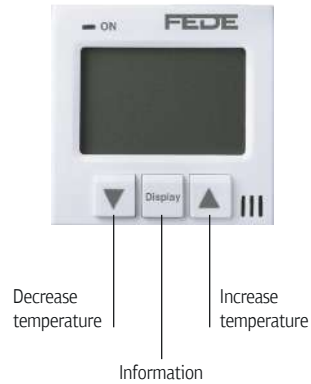

This thermostat provides simple and intuitive temperature management, whose current settings are displayed on a large LCD. Thanks to the built-in RGB, the thermostat display changes color according to the operating mode: when the heating mode is activated, the display will light blue. The set temperature and the actual temperature are shown alternately on the display; pressing the "DISPLAY" button will only display the actual temperature, and pressing the button again will re-activate the information collation mode.

There are two versions of thermostat available:

- FD18000** — to control the floor temperature.
- FD18001** — to control the room air temperature.

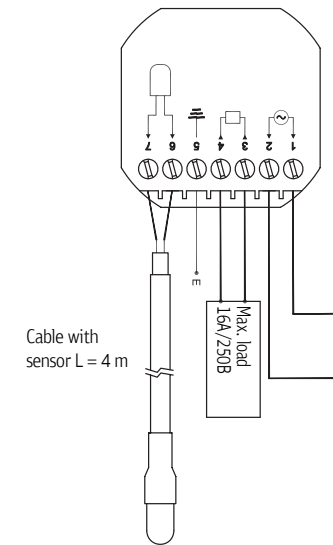

Multifunctional thermostat FD18004

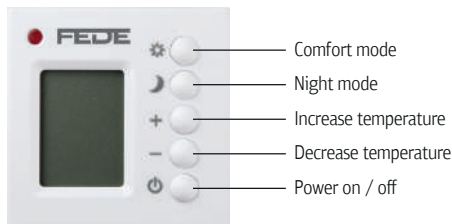

This thermostat allows the previous programming of two modes of operation: economic and comfort. The modes are selected by clicking on corresponding buttons. The LCD displays the current thermostat setting.

This thermostat can operate in the following modes:

- floor temperature control.
- air temperature control.
(for example, when connecting electric radiators)
- combined mode

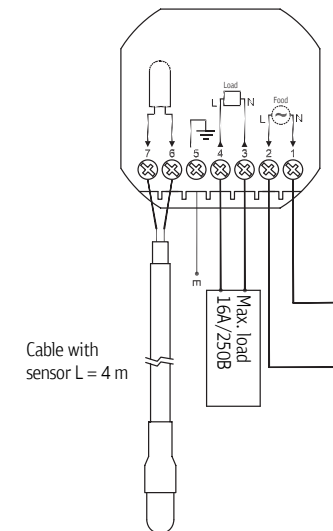

MECHANISM CONNECTION DIAGRAMS FOR POWER TV SOCKET OUTLETS

There are two types of television signal wiring for several users: the parallel circuit ("star" wiring) and the series circuit.

In the first case the dividers, also called separators, are used, which are responsible for equitably dividing the power of the input signal into 2, 3 and 4; although it should be noted that for each division in 2 the power of the signal for each output also decreases by half (actually even a little more: the signal drop is usually 3.5-4.5 dB). This method of wiring provides a great uniformity of power in the television frequency band and a great insulation between the terminals, however, it requires more cables.

In the second case the couplers are used and the television channels are connected in series (cascade) one after another. This type of wiring offers unequal division of the signal. Such a wiring method provides uneven division of the signal, is easier to implement and requires fewer cables. However, when this scheme is implemented the signal reaches a lower number of TV receivers.

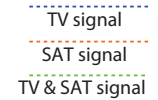

EXAMPLE OF USING THE FD220F PLUG BASE TO CREATE A "WATERFALL" TV / SATELLITE NETWORK WITH AN IF-IF CABLE

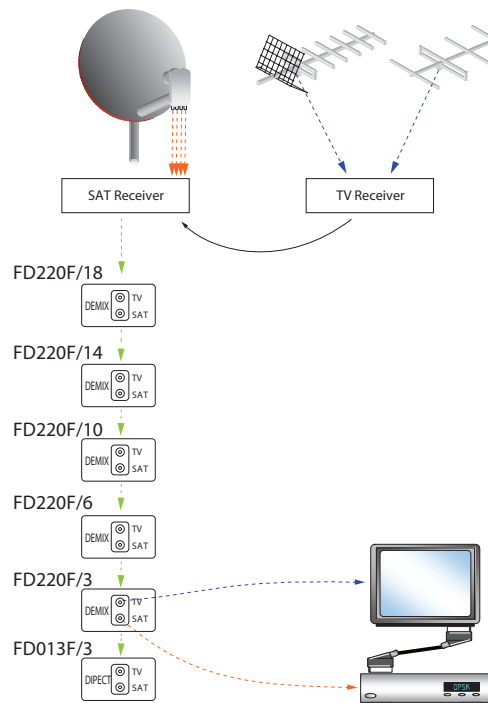

EXAMPLE OF USE OF FD010F PLUG BASES TO CREATE A "STAR" TYPE TV / SATELLITE NETWORK

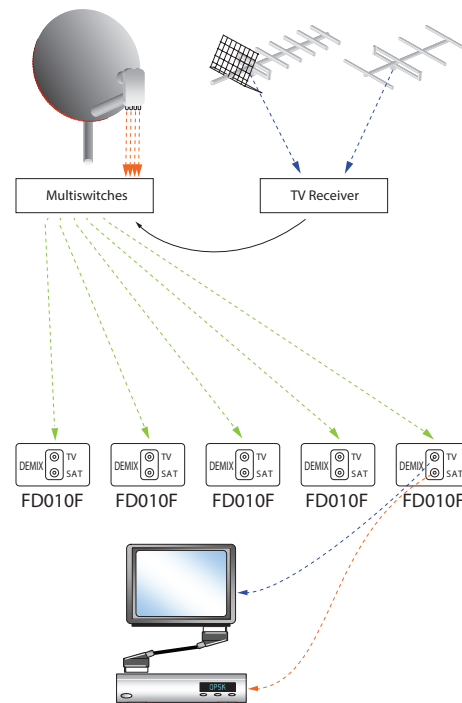

EXAMPLE OF USE FD011F SOCKET OR "ECOCOMPACT" KIT TO CREATE THE TV / SATELLITE NETWORK

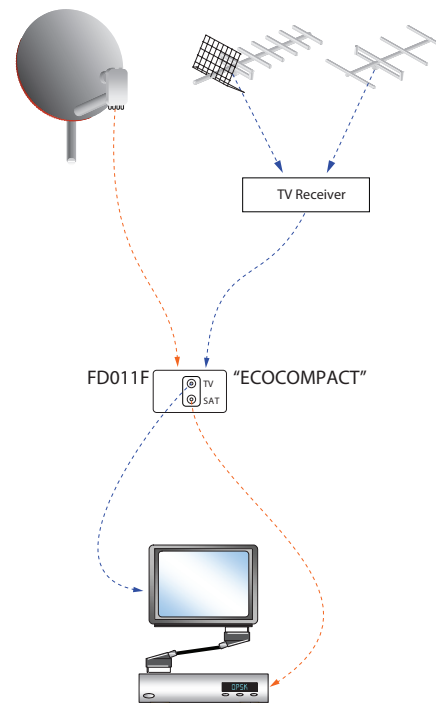

EXAMPLE OF USE FD506F AND FD002F SOCKETS TO ESTABLISH A "WATERFALL" TV NETWORK AND THE DIRECT CONNECTION OF TV SATELLITE

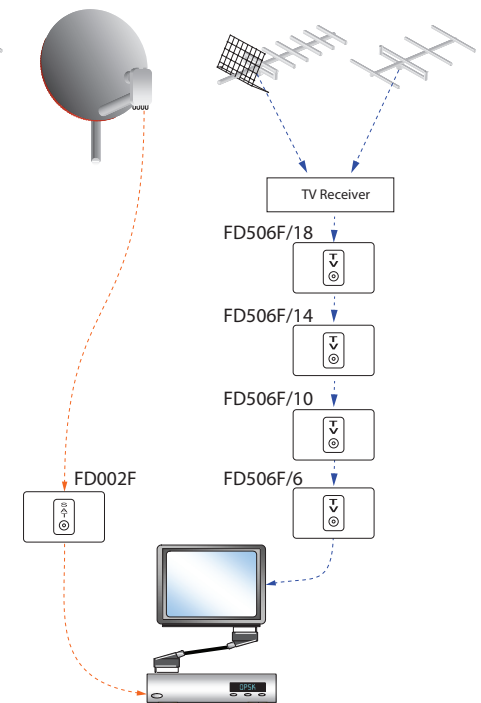

SoHo collection

“Brass is the new Black &
the ultimate sophistication”



We reserve the right to carry out modifications on our models, sizes, finishes and on the information contained in the present CATALOGUE without prior notice. Copying this CATALOGUE is expressly forbidden without our consent. Nous nous réservons le droit de réaliser des changements dans nos modèles, nos tailles, nos finitions et dans les formations contenues dans le CATALOGUE ci-présent sans avis préalable. La copie de ce CATALOGUE est formellement interdite sans notre accord préalable.

Ci riserviamo il diritto di apportare cambiamenti nei nostri modelli, dimensioni, finiture e le informazioni contenute in questo CATALOGO senza preavviso. Copiare questo catalogo è espressamente proibito senza il nostro consenso. Nos reservamos el derecho a realizar modificaciones en nuestros modelos, tamaños, acabados y sobre la información contenida en el presente CATALOGO sin previo aviso. La copia de este catálogo está expresamente prohibida sin nuestro consentimiento. Wir behalten uns das Recht Änderungen vorzunehmen in unseren Modellen, Größen, Ausführungen und die Informationen in diesem Katalog ohne vorherige Ankündigung. Die Kopie dieses Katalogs ist ohne unsere Zustimmung nicht gestattet. Компания FEDE оставляет за собой право модифицировать указанные в данном каталоге устройства, их размеры, цвета, декоративные покрытия и технические характеристики без предварительного уведомления. Копирование информации и изображений из данного каталога без предварительного согласия компании FEDE запрещено!



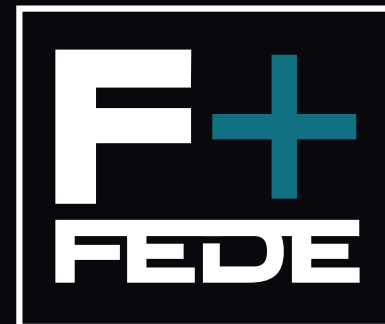

HEADQUARTERS & SHOWROOM

Av. Llenguadoc, 45-47 · (08915) Badalona · (Barcelona) SPAIN · Phone +34 934 183 856 · info@fedepius.com

www.fedepius.com

C2019 #001

SoHo
collection